

Evaluation of Infrastructure Facilities for Nashik City

3.1 Preamble

Due to the discharges of liquid wastes in river Godavari and its tributaries, the pollution levels are exceeding beyond the permissible guideline values for water quality. Hence, detailed investigation of prevailing environmental quality for water bodies within study area was taken up for pre and post monsoon seasons. While selecting the locations, the point and non point sources of pollution were considered. The collection of water samples from riverine stretch is preferred to be carried out from the bridges in the mid stream to assess the quality as it represents water quality after proper dilution, dispersion and mixing of the pollutants. The water environment is distributed in various categories viz. dam, rivers, tributaries and nallas. The sampling locations for dam, river and tributaries are presented in **Figure 3.1** and area wise assessment is presented in **Plates A to C** respectively.

3.2 Dam Water Quality

Sampling locations for selected dams during survey is given in **Table 3.1**.

Table 3.1: Sampling Locations at Dam Site

Sample Description	Codes	Latitude (N)	Longitude (E)
Kushawart	D1	32 ⁰ 24'53.0"	77 ⁰ 14'09.0"
Gautami Godavari	D2	19 ⁰ 59'18.4"	73 ⁰ 34'30.3"
Kashyapi	D3	20 ⁰ 04'57.2"	73 ⁰ 36'24.6"
Gangapur Dam Intake Well	D4	20 ⁰ 02'21.2"	73 ⁰ 40'48.5"
Nandur Madhyameshwar Dam	D5	20 ⁰ 00'27.5"	74 ⁰ 07'59.5"

The methodology of sampling preservation and analysis of relevant parameters selected is elaborated in **Annexure 9**. Physico-chemical analysis for pre and post monsoon season water quality for dam is presented in **Table 3.2a and b** respectively.

a) Water Quality during Pre and Post Monsoon Season

Water samples from five locations namely, Kushawarta, Gautami dam, Kashypi Dam, Gangapur Dam Intake well, and Nandur Madhyameshwar Dam has been considered for evaluation. However, water sample from Kashypi dam could not be collected during pre monsoon due to scarcity and non availability of water. The analytical results for dam water are compared with the Standards of Drinking water as per IS:10500-2012 as well as Water Quality Standards for 'Best Designated Usages' A-I class by MPCB (**Annexure 10a & c**).



Figure 3.1a: Study Area

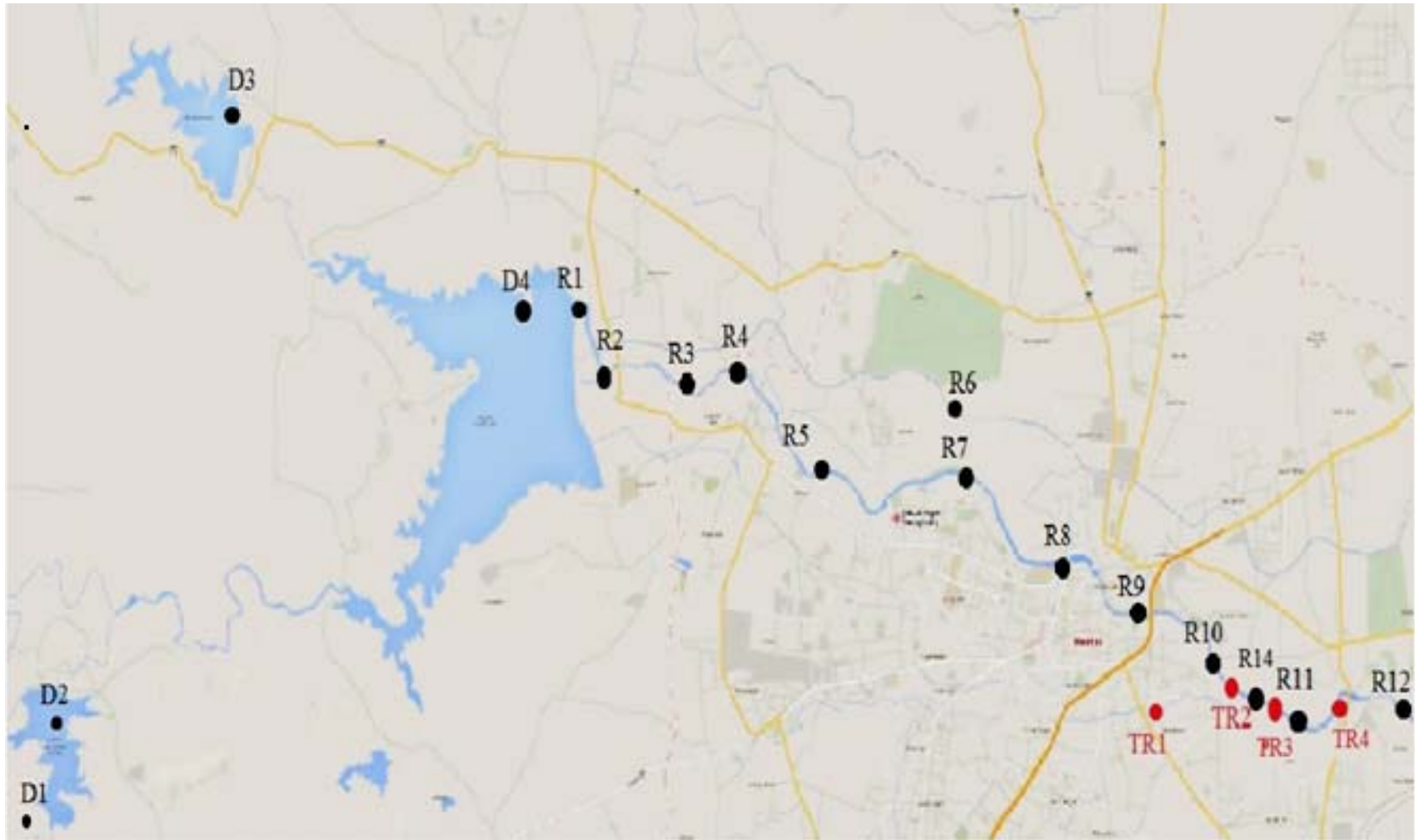

Figure 3.1b : Sampling Locations for Water Quality Assessment of Dam, River and Tributaries



Figure 3.1c: Sampling Locations for Water Quality Assessment of Dam, River and Tributaries

A. Assessment of Dam Water Quality



River Godavari at Kushavarta



River Godavari at Kashyapi Dam

B. River Stretch from Downstream of Gangapur Dam to Nandur Madhyameshwar



River Godavari at Anandvalli Bridge



River Godavari at Ramkund



River Godavari at Talkuteshwar Bridge



River Godavari at Godavari Kapila



River Godavari at Dasak Bridge



**River Godavari at Saikheda Chanduri
Bridge Confluence**

Table 3.2a: Physico-chemical Characterization of Dam Water Samples for Godavari (Pre –monsoon Season)

Sr.	Parameters	D-1	D-2	D-3*	D-4	D-5	BIS 10500: 2012		MPCB A-I Class limits
							Acceptable	Permissible	
Physical									
1.	Ambient Temperature °C	27	28	-	28.5	29.5	-	-	
2.	pH	6.0	7.0	-	7.2	7.0	6.5 – 8.5	NR	6.5 – 8.5
Inorganic									
3.	Electrical Conductivity	360	260	-	210	330	-	-	-
4.	Total Dissolved Solids	252	195	-	158	231	500	2000	-
5.	Total Alkalinity as CaCO ₃	233	193	-	147	215	200	600	-
6.	Sulphates as SO ₄	5.5	3.9	-	4.1	7.7	200	400	-
7.	Nitrates as NO ₃	BDL	BDL	-	BDL	BDL	45	NR	45
Pollutant									
8.	Ammonical Nitrogen as NH ₃ -N	4.7	BDL	-	BDL	BDL	0.5	-	1.5
9.	Total Phosphate as PO ₄ -P	BDL	BDL	-	BDL	0.6	-	-	
10.	DO	0.6	8	-	8	8.2	-	-	Not less than 5 mg/L
11.	BOD	18	4.6	-	3.5	9.8	-	-	2.0 mg/L
Microbiology									
12.	Total Coliform	12 x 10 ²	150	-	Nil	18x 10 ⁴	-	-	Coliform bacteria 250
13.	E.coli	60	40	-	Nil	11 x 10 ²	-	-	-

Note: Minimum Detectable Limit For parameters tested is as under: (PO₄-0.05, BOD-1.0, COD-5.0, Nitrate: 1.0, NH₃N: 0.2)

All samples are colourless and odourless. *- Sample could not be taken since the point had almost dried up.

Values except Temp, EC expressed as mg/l and microbial CFU/100 ml

DO- Dissolved Oxygen, BOD- Biochemical Oxygen Demand, TC- Total Coilforms, EC- E.coli, BDL- Below Detectable Limit

Table 3.2b : Physico-chemical Characterization of Dam Water Samples for Godavari (Post –monsoon Season)

Sr.	Parameters	D-1	D-2	D-3	D-4	D-5	IS 10500: 2012		MPCB A-I Class limits
							Acceptable	Permissible	
Physical									
1.	Ambient Temperature °C	19	22	25	25	21	-	-	
2.	pH	7.5	7.6	7.7	7.6	6.7	6.5 – 8.5	NR	6.5 – 8.5
Inorganic Parameters									
3.	Electrical Conductivity	274	163	109	183	318	-	-	
4.	Total Dissolved Solids	164	99	65	110	191	500	2000	-
5.	Total Alkalinity as CaCO ₃	120	77	51	92	115	200	600	-
6.	Sulphates as SO ₄	110	73	50	87	122	200	400	-
7.	Nitrates as NO ₃	15	7	6	7	22	45	NR	45
Pollutant									
8.	Ammonical Nitrogen as NH ₃ -N	1.9	BDL	0.3	0.7	0.8	0.5	-	1.5
9.	Total Phosphate as PO ₄ -P	BDL	BDL	BDL	BDL	0.1	-	-	
10.	DO	0	7.1	8.2	6.5	6.4			Not less than 5 mg/L
11.	BOD	75	4	5.0	5.0	5.0			2.0 mg/L
Microbiology									
12.	Total Coliform	18×10 ²	0	0	5×10 ²	1×10 ²	-	-	Coliform bacteria 250
13.	E.coli	14×10 ²	0	0	20	60			-

Note: Minimum Detectable Limit For parameters tested is as Under: (PO₄-0.05, BOD-1.0, COD-5.0, Nitrate: 1.0, NH₃N: 0.2)

All samples are colourless and odourless. *- Sample could not be taken since the point had almost dried up.

Values except for Temp, EC expressed as mg/l and microbial CFU/100 ml

DO- Dissolved Oxygen, BOD- Biochemical Oxygen Demand, TC- Total Coilforms, EC- E.coli, BDL- Below Detectable Limit

b) Observations on Dam Water Quality

i) Pre Monsoon

Physical: The water samples collected from the dams show pH in the range of 6 to 7.2, indicating that water quality at Kushwarat is not up-to the prescribed standards of Water Quality Standards for 'Best Designated usages' by MPCB as well as Standards for Drinking Water as per IS:10500-2012. This could be due to various activities like washing, bathing, occurring at upstream region of this point. Deterioration in the quality has resulted in increased concentration of pollutants which may also be due to small quantity of fresh water inputs.

Inorganic: The Total Dissolves Solids [TDS] which constitutes summation of all dissolved cations and anions, of the water samples were within the acceptable range prescribed by Standards for Drinking Water.

Other inorganic parameters like Total Alkalinity, Sulphates, and Nitrates comply with the prescribed standards of BIS: 10500-2012 and **A-I** Class Limits by MPCB.

Organic & Nutrient: At temperature of 27-30°C, the dissolved oxygen levels in the water are in the range of 0.6 – 8.2 mg/L. Lowest DO of 0.6 mg/L was observed at Kushwarat indicating heavy organic pollution due to activities such as bathing, floating wastes in the form of flowers. Other dam water samples show high DO level indicating no pollution.

The Biological Oxygen Demand [BOD] ranged from 3.5 to 18 mg/L. Kushwarat and Nandur Madhyameshwar show higher level of BOD of 18 mg/L and 9.8 mg/L respectively. This is an indicator of pollution and presence of organic matter.

Nutrient Parameters like ammonia nitrogen is well within the MPCB prescribed limits of A-I class limits given by MPCB for all except Kushwarat. Phosphates as well as microbiological parameters do not indicate significant pollution due to human activity.

ii) Post-monsoon

Physical: The water samples show pH in the range of 6.7- 7.7 which are well within the prescribed limits of Standards.

Inorganic: The Total Dissolves Solids [TDS] which constitutes summation of all dissolved cations and anions, of the water samples were within the acceptable range of 500 mg/L- 2000 mg/L as prescribed by Standards. Parameters like Total Alkalinity, Sulphates, Nitrates, Chlorides, Total Hardness show values well within the prescribed in both standards.

Organic & Nutrient: At temperature around 19 – 25°C, the dissolved oxygen values vary from zero to 8.2 mg/L while the Biological Oxygen Demand [BOD] vary in the range of 4-75 mg/L. All values for DO and BOD, except that of Kushwarat comply with the prescribed Standards

At Kushwarat, the dissolved oxygen level is zero which is indicative of very high pollution load also reflected in high BOD of 75 mg/L. Other parameters like phosphates and microbiology show mild pollution. Ammonical Nitrogen show elevated concentration at Kushwarat indicating human pollution.

iii) Trace Metals

The concentration of trace metal is given in **Table 3.3** and standards and permissible limits are given in **Annexure 10c**.

Table 3.3: Analytical Result for Heavy Metal Analysis of Dam on River Godavari

Sample description	Code	Cu	Ni	Fe	Mn	Zn	Pb	Cd	Cr
Kushavarat	D1	0.04	BDL	0.31	0.11	0.35	BDL	0.03	BDL
Gautaumi dam	D2	0.04	BDL	0.25	0.06	0.47	BDL	0.03	BDL
Kashypi dam	D3	0.08	BDL	0.40	0.19	0.15	BDL	0.03	BDL
Gangapur intake well	D4	0.03	BDL	0.27	0.04	0.13	BDL	0.03	BDL
Nandur-Madhyameshwar Dam	D5	0.04	BDL	0.24	0.10	0.42	BDL	0.03	BDL

All values expressed as mg/l, BDL – Below Detectable Limits as given by APHA

It was observed that concentration of all the trace metals of environmental concern in the dam waters was found to be low and thus do not pose any harm by its consumption.

3.3 River Water Quality

The river Godavari was monitored at 15 locations a covering a stretch from Gangapur dam till upstream of Nandur Madhyameshwar. As explained earlier the water samples were collected from the bridges in the mid stream. At certain locations local boat was used to carry out sampling. **Table 3.4** presents the sampling locations covered during Pre and post monsoon survey in 2013 -2014. The corresponding MPCB sampling code is also provided.

Table 3.4: Sampling Locations at River Stream

Sample codes	Sample Description	Latitude (N)	Longitude (E)	MPCB Code#
Gangapur Dam Downstream	R-1	20 ⁰ 02'55.7"	73 ⁰ 40'49.9"	1095
Balaji Mandir	R-2	20 ⁰ 03'15.8"	73 ⁰ 43'00.1"	
Anandvalli Bridge	R-3	20 ⁰ 01'12.3"	73 ⁰ 44'46.0"	
Asarambapu Bridge	R-4	20 ⁰ 01'45.5"	73 ⁰ 43'24.9"	
Hanuman ghat	R-5	20 ⁰ 00'31.7"	73 ⁰ 47'10.4"	2179
Holkar Bridge	R-6	20 ⁰ 00'34.7"	73 ⁰ 47'24.7"	
Ramkund	R-7	20 ⁰ 00'33.3"	73 ⁰ 47'29.1"	1096
Asthi Visarjan	R-8	20 ⁰ 00'33.3"	73 ⁰ 47'29.1"	
Talkuteshwar Bridge	R-9	20 ⁰ 00'09.0"	73 ⁰ 47'49.8"	
Godavari River near Tapovan	R-10	19 ⁰ 59'56.5"	73 ⁰ 48'57.8"	2180
Godavari River downstream of Nashik	R-11	19 ⁰ 59'41.5"	73 ⁰ 49'04.8"	1211
Dashak Bridge	R-12	19 ⁰ 59'49.4"	73 ⁰ 50'49.4"	
Chandori Saikheda Bridge	R-13	20 ⁰ 0'38.8"	74 ⁰ 00'18.2"	2182
Kapila Sangam	R-14	19 ⁰ 59'47.5"	73 ⁰ 49'11.8"	2181
Karanjgaon Bridge	R-15	20 ⁰ 01'18.7"	74 ⁰ 04'19.2"	

The list of sampling Locations decided by MPCB under NWMP, SWMP, IDW and IWIN are presented in Annexure 10d.

The secondary data provided by NMC on river water quality is presented in **Annexure 11a and b**. Physico-chemical analysis for pre and post monsoon season water quality for rivers are presented in **Table 3.5a and b** respectively.

a) Observations and Interpretation of River Water for the Pre and Post Monsoon

Total 15 water samples from the river stretch within study area were collected from downstream of Gangapur dam upto Chandori Saikheda Bridge near Nandur Madhumeswar. Most of the locations selected are also monitored regularly by MPCB under GEMS and MINARs programme. Sample at Kapila Sangam could not be collected due to significant release of water from Gangapur dam during pre-monsoon. Water samples were collected from bridges wherever possible. The results are compared with the Standards of Drinking water as per IS:10500-2012 as well as Water Quality Standards for 'Best Designated usages' A-II class by MPCB.

i) Pre-monsoon

Physical: The river water stretch extends from downstream of Gangapur Dam upto Chandori Saikheda and Nandur Madhumeswar. pH of water samples was varying from 7.0 -9.1.

Table 3.5a : Physico-chemical Characterization of River Water Samples for Godavari (Pre –monsoon Season)

Sr.	Parameters	R-1	R-2	R-3	R-4	R-5	R6	R7	R8	BIS 10500: 2012		MPCB A-II Class limits
										Acceptable	Permissible	
Physical & Inorganic												
1.	Ambient Temperature °C	29	32	32	32	32	31	31	34	-	-	
2.	pH	7.1	7.1	7.3	7.0	8.0	7.0	9.1	8.8	6.5 – 8.5	NR	6.5 – 8.5
3.	Electrical Conductivity	270	230	220	250	250	270	240	340	-	-	
4.	Total Dissolved Solids	202	172	165	189	187	202	180	255	500	2000	-
5.	Total Alkalinity as CaCO ₃	185	170	146	177	168	165	172	194	200	600	-
6.	Sulphates as SO ₄	3.3	4.1	BDL	3.1	5.5	5.1	4.7	7.7	200	400	400
7.	Nitrates as NO ₃	BDL	BDL	BDL	BDL	BDL	BDL	BDL	BDL	45	NR	45
Pollutants and Microbiology												
8.	Amonical Nitrogen as NH ₃ -N	BDL	1.2	1.0	0.7	0.8	1.9	2.6	0.4	0.5	-	1.5
9.	Total Phosphate as PO ₄ -P	B	BDL	BDL	BDL	BDL	BDL	BDL	BDL	-	-	
10.	DO	8.9	8.2	8.6	8.7	8.1	8.1	9.5	7.2			
11.	BOD	4.2	2.4	2.0	2.8	5.4	4.6	5.8	8.5			5 or below 5
12.	Total Coliform	4000	TNC	TNC	TNC	5000	TNC	TNC	TNC	-	-	Not greater than 5000 (MPN)
13.	E.Coli	1700	8000	8000	1500	4000	7000	TNC	2000			

Note: Minimum Detectable Limit For parameters tested are as under (PO₄-0.05, BOD-1.0, COD-5.0, NH₃-N-0.2)

All samples are colourless and odourless.

*- Samples at could not be collected as significant water was released from Gangapur Dam

Values except Temp, EC expressed as mg/l and microbial CFU/100 ml

DO- Dissolved Oxygen, BOD- Biochemical Oxygen Demand, TC- Total Coilforms, EC- E.coli, BDL- Below Detectable Limit

Table 3.5a (Contd.): Physico-chemical Characterization of River Water Samples for Godavari (Pre –monsoon Season)

Sr.	Parameters	R9	R10	R11	R12	R13	BIS 10500: 2012		MPCB A-II Class limits
							Acceptable	Permissible	
Physical & Inorganic									
1.	Ambient Temperature °C	32	31	30	32	30.5			
2.	pH	8.5	8.0	7.0	6.5	6.8	6.5 – 8.5	NR	6.5 – 8.5
3.	Electrical Conductivity	340	860	780	350	290	-	-	
4.	Total Dissolved Solids	255	645	585	260	217	500	2000	-
5.	Total Alkalinity as CaCO ₃	233	470	443	215	212	200	600	-
6.	Sulphates as SO ₄	2.5	11.7	16.8	13.7	7.7	200	400	400
7.	Nitrates as NO ₃	BDL	BDL	BDL	1.2	BDL	45	NR	45
Pollutants and Microbiology									
8.	Ammonical Nitrogen as NH ₃ -N	2.7	2.7	3.1	2.5	1.9	0.5	-	1.5
9.	Phosphate as PO ₄ -P	BDL	1.3	1.0	4.8	BDL	-	-	
10.	DO	1.01	4.2	4.7	4.1	8.5			
11.	BOD	6.2	9.0	23.5	16	11.5			5 or below 5
12.	Total Coliform	9000	TNC	TNC	TNC	TNC	-	-	Not greater than 5000 (MPN)
13.	E.Coli	4000	TNC	TNC	TNC	TNC			

Note: Minimum Detectable Limit For parameters tested is as under (PO₄-0.05, BOD-1.0, COD-5.0, NH₃-N-0.2)

All samples are colourless and odourless.

R14 and R15 could not be collected during pre monsoon season

Values except Temp, EC expressed as mg/l and microbial CFU/100 ml

DO- Dissolved Oxygen, BOD- Biochemical Oxygen Demand, TC- Total Coilforms, EC- E.coli, BDL- Below Detectable Limit

Table 3.5b : Physico-chemical Characterization of River Water Samples for Godavari (Post monsoon Season)

Sr.	Parameters	R-1	R-2	R-3	R-4	R-5	R6	R7	R8	BIS 10500: 2012		MPCB A-II Class limits
										Acceptable	Permissible	
Physical & Inorganic												
1.	Ambient Temperature °C	21	21	22	21	22	22	23	22	-	-	
2.	pH	7.1	6.9	7.4	7.2	7.3	7.4	7.5	7.7	6.5 – 8.5	NR	6.5 – 8.5
3.	Electrical Conductivity	220	260	392	462	608	621	623	625	-	-	
4.	Total Dissolved Solids	132	156	235	277	365	373	374	375	500	2000	-
5.	Total Alkalinity as CaCO ₃	106	109	158	185	224	240	242	240	200	600	-
6.	Sulphates as SO ₄	1.6	10	22	23	33	26	31	35	200	400	400
7.	Nitrates as NO ₃	BDL	1.1	1.7	1.6	1.2	BDL	BDL	BDL	45	NR	45
Pollutants and Microbiology												
8.	Ammonical Nitrogen as NH ₃ -N	BDL	0.48	0.33	0.40	1.7	1.9	1.6	1.9	0.5	-	1.5
9.	Phosphate as PO ₄ -P	BDL	BDL	0.2	0.05	0.3	0.28	0.32	0.27	-	-	
10.	DO	8.4	8.5	7.8	7.4	6.8	6.1	6.9	2.5			
11.	BOD	3.5	3	5	4	9.4	7.4	8	7			5 or below 5
12.	Total Coliform	3000	5x10 ²	11x10 ²	9x10 ²	7x10 ²	10x10 ²	12x10 ²	12x10 ²	-	-	Not greater than 5000 (MPN)
13.	E.Coli	100	2x10 ²	9x10 ²	6x10 ²	4x10 ²	5x10 ²	10x10 ²	9x10 ²			

Note: Minimum Detectable Limit For parameters tested is as under (PO₄-0.05, BOD-1.0, COD-5.0, NH₃-N-0.2)

All samples are colourless and odourless.

*- Samples at could not be collected as significant water was released from Gangapur Dam

Values except Temp, EC expressed as mg/l and microbial CFU/100 ml

DO- Dissolved Oxygen, BOD- Biochemical Oxygen Demand, TC- Total Coilforms, EC- E.coli, BDL- Below Detectable Limit

Table 3.5b (Contd.) : Physico-chemical Characterization of River Water Samples for Godavari (Post Monsoon Season)

Sr.	Parameters	R9	R10	R11	R12	R13	R14	R15	BIS 10500: 2012		MPCB A-II Class limits
									Acceptable	Permissible	
Physical & Inorganic											
1.	Ambient Temperature °C	24	23	25	25	24	25	25	-	-	
2.	pH	7.7	7.3	7.5	7.3	6.8	6.9	6.8	6.5 – 8.5	NR	6.5 – 8.5
3.	Electrical Conductivity	623	641	714	783	324	703	510	-	-	
4.	Total Dissolved Solids	373	385	428	470	195	422	306	500	2000	-
5.	Total Alkalinity as CaCO ₃	234	251	278	309	123	205	160	200	600	-
6.	Sulphates as SO ₄	38	30	28	37	16	22	18	200	400	400
7.	Nitrates as NO ₃	BDL	BDL	BDL	BDL	1.7	BDL	1.1	45	NR	45
Pollutants and Microbiology											
8.	Amonical Nitrogen as NH ₃ -N	1.3	2.3	3.1	3.4	3.0	3.0	1.9	0.5	-	1.5
9.	Total Phosphate as PO ₄ -P	0.22	0.4	1.30	1.60	0.37	1.50	0.80	-	-	
10.	DO	5.7	0.8	5.1	1.0	6.3	2.0	3.2			
11.	BOD	9	98	7	42	3	75	40			5 or below 5
12.	Total Coliform	11x10 ²	14x10 ²	18x10 ²	20x10 ²	2x10 ²	TNC	5x10 ²	-	-	Not greater than 5000 (MPN)
13.	E.Coli	7x10 ²	9x10 ²	11x10 ²	8x10 ²	8x10 ²	14x10 ²	7x10 ²			

Note: Minimum Detectable Limit For parameters tested is as under (PO₄-0.05, BOD-1.0, COD-5.0, NH₃-N-0.2)

All samples are colourless and odourless.

Values except Temp, EC expressed as mg/l and microbial CFU/100 ml

DO- Dissolved Oxygen, BOD- Biochemical Oxygen Demand, TC- Total Coilforms, EC- E.coli, BDL- Below Detectable Limit

Higher pH variation especially at places like Ramkund, Asthi viasarjan and Talkuteshwar bridge, can be due to various factors like washing of clothes on the river banks using materials with high soda content, immersion of ashes from crematorium and other activities. The remaining water samples show pH well within the prescribed standards by MPCB and BIS: 10500-2012.

Inorganic: The Total Dissolves Solids [TDS] which constitutes summation of all dissolved cations and anions, of the water samples were within the acceptable range of 500-2000 mg/L. Water at Godavari River downstream of Tapovan STP shows levels higher than the acceptable range but within the permissible limits of Standards prescribed. This may be due to mixing of treated wastewater from the STP.

Total Alkalinity, is within the standard limit prescribed by BIS: 10500-2012, except for location at Godavari River near Tapovan, and Godavari River downstream of Nashik where the values for alkalinity exceeded the acceptable limit but were within the Permissible limits. Higher values of alkalinity may attribute to domestic wastewater releases. At Ramkund, Asthi visarjan could be a major contributor towards increased alkalinity levels. Parameters like sulphates, nitrates are within the accepted limits of BIS: 10500-2012 and A-II Class limits by MPCB.

Organic Nutrient & Microbial Parameters: At temperature of around 29°C - 34°C, dissolved oxygen show varying levels from 7.9- 9.5 mg/L. Such high levels of DO could also be contributed by presence of algae. The area near Ramkund had profuse algal growth. High DO levels when compared to temperature were observed at places like Anandvalli bridge, Aasaram Bapu bridge, Holkar bridge, Ramkund and Talkuteshwari bridge.

The Biochemical Oxygen Demand [BOD] is observed to be within limits upto Asaram Bapu bridge, after which BOD is observed to be increasing more than the permissible limits prescribed by A-II class limits by MPCB. Highest BOD levels were found to be at Godavari river downstream Tapovan STP and at Chandori-Saikheda. This could be due to the mixing of treated sewage, stagnant water as well as domestic wastewater from various places.

Phosphates shows low levels while ammonical nitrogen shows high concentration at Godavari downstream of Tapovan STP, Godavari near Tapovan, Ramkund and Dasak Bridge. These high levels indicate pollution due to human waste, presence of sewage which could be due to mixing of treated sewage in river.

Microbiology parameters like Total coliforms, E.coli show elevated levels exceeding the limits prescribed by A-II class by MPCB. Presence of such microbes indicates pollution load and contamination due to sewage.

ii) Post-monsoon

Total 15 riverine samples were collected from Gangapur dam downstream up-to Karanjgaon. Water samples were collected from bridges wherever it was possible.

The Standards for Drinking Water as per IS:10500-2012 & Water Quality Standards for 'Best Designated usages' A-II class by MPCB have been considered.

Physical: The water samples in the river stretch considered from Gangapur dam downstream upto Karanjgaon exhibit pH well within the prescribed range by MPCB for A-II class limits and BIS:10500-2012.

Inorganic: The Total Dissolves Solids [TDS] which constitutes summation of all dissolved cations and anions, of the water samples were within the acceptable range of 500 mg/L- 2000 mg/L as prescribed by Standards for Drinking Water as per IS:10500-2012. The total Alkalinity, sulphates, nitrates show values were also within the permissible limits as given of BIS:10500-2012.

Organic, Nutrient & Microbial Parameters: At temperature of around 21-25°C, the dissolved oxygen levels are observed in the range of 0.8 to 8.5 mg/L. The dissolved oxygen level was found to be 0.8 at Godavari near Tapovan and 1.0 at Dasak bridge indicating high pollution load while DO was observed to be 2 mg/L at Kapila Sangam indicating presence of untreated sewage released. Dissolved oxygen higher than expected value of temperature is contributed by presence of algae.

The Biochemical Oxygen Demand(BOD) of the water samples are observed to be within limits up-to Asaram bapu bridge after which steady increase is observed with the highest levels at Godavari near Tapovan and Kapila sangam. Sewage released from the STP outlet is be responsible for such high increase in BOD. While at Kapila sangam it was observed that untreated sewage was released directly into the river resulting in significant pollution.

Microbiological parameters show presence of coliforms within the permissible limit by A-II class limits by MPCB.

iii) Trace Metals

The trace metals of environmental concerns were analyzed during post monsoon season are presented in **Table 3.6**.

Table 3.6: Analytical Result for Heavy Metal Analysis of Dam on River Godavari

Sample Description	Sample Code	Cu	Ni	Fe	Mn	Zn	Pb	Cd	Cr
Balaji Mandir	R2	0.06	BDL	0.02	0.06	0.73	BDL	0.01	BDL
Anandvalli bridge	R3	0.18	0.04	0.33	0.05	0.78	0.01	0.04	BDL
Aasaram bapu Bridge	R4	0.05	BDL	0.43	0.08	0.93	BDL	0.02	BDL
Hanuman Ghat	R5	0.07	0.05	0.24	0.08	0.36	BDL	0.02	BDL
Holkar Bridge	R6	0.06	0.04	0.56	0.15	0.85	BDL	0.03	BDL
Ramkund	R7	0.08	BDL	0.88	0.31	0.42	BDL	0.03	BDL
Asthi visarjan	R8	0.06	BDL	0.33	0.17	0.27	BDL	0.03	BDL
Talkuteshwari bridge	R9	0.04	BDL	0.34	0.17	0.33	BDL	0.03	BDL
Godavari at Tapovan	R10	0.06	0.035	0.45	0.21	0.18	BDL	0.03	BDL
Godavari at downstream of Tapovan	R11	0.04	BDL	0.52	0.13	0.22	BDL	0.03	BDL
Dasak	R12	0.10	BDL	0.39	0.18	0.77	BDL	0.03	BDL
Chandori Saikheda Bridge	R13	0.11	BDL	0.53	0.10	0.85	BDL	0.03	BDL
Kapila Sangam	R14	0.11	BDL	0.40	0.12	0.80	BDL	0.02	BDL
Karanjagaon Bridge	R15	0.09	BDL	0.45	0.13	0.79	BDL	0.02	BDL

The water samples in the riverine stretch show low concentration of heavy metal which does not indicate any contamination from industrial discharges. The standards considered are as prescribed by CPCB for inland surface water. The impact of Nasardi river which is likely to carry trace metals from industrial zone is not observed. When the pH of water sample is near neutral or alkaline most of the trace metals precipitate as suspended hydroxide form and settle down in the sediments.

3.4 Tributaries of River Godavari

Mainly three tributaries viz. Waldevi, Darna and Nasardi were considered since they are within the study stretch of river Godavari. These tributaries were studied and samples were also taken at upstream and downstream of confluence to analyze the water quality and the impact of releases of pollutants from Nashik on Godavari. Waldevi river arises from Waldevi dam which meets Darna. Darna River arises from Mukane dam and extends to join Godavari. Nasardi river starts near Trimbak and extends upto Tapovan meeting Godavari at downstream of the STP. The sampling locations are presented in **Table 3.7 (Figure 3.1)** and the area wise assessment is presented in **Plates**.

Table 3.7: Sampling Locations of Tributaries Meeting River Godavari in Nashik

Sample Description	Sample Code	Latitude[N]	Longitude[E]
River Nasardi			
Nasardi River	TR1	19 ⁰ 49'08.12"	73 ⁰ 47'02.95"
Godavari Upstream of Nasardi	TR2	19 ⁰ 59'25.45"	73 ⁰ 49'15.47"
Confluence of Godavari-Nasardi	TR3	19 ⁰ 59'22.86"	73 ⁰ 49'21.74"
Godavari downstream of confluence with Nasardi	TR4	19 °59'41.5"	73 °49'04.8"
Waldevi			
Waldevi river at Bagul nagar	TR5	19 ⁰ 56'08.92"	73 ⁰ 50'22.29"
Waldevi river bridge over vitgaon	TR6	19 ⁰ 56'13.28"	73 ⁰ 48'59.06"
Waldevi-darna Confluence	TR7	19 ⁰ 55'50.08"	73 ⁰ 51'22.90"
River Darna Downstream of Waldevi-Darna Confluence	TR8	19 ⁰ 55'52.03"	73 ⁰ 51'30.87"
Darna			
Jakhori bridge on darna	TR9	19 ⁰ 57'04.46"	73 ⁰ 55'05.79"
Palase bridge on Darna	TR10	19 ⁰ 49'08.12"	73 ⁰ 47'02.95"
Darna-Godavari confluence	TR11	19 ⁰ 58'37.27"	73 ⁰ 57'00.40"
Downstream of Darna-Godavari confluence (Chanduri Saikheda)	TR12	20 ⁰ 0'38.8"	74 ⁰ 00'18.2"

The results of samples of three tributaries and upstream and downstream of confluence are presented in **Table 3.8**.

a) Observations on Tributaries of River Water

The purposes of collecting samples at pre determine locations were to evaluate the pollutional status of tributaries vis-à-vis their resultant impact on river Godavari.

- **Physical:** The water samples show pH in the range of 6.8 – 7.5 which are within the acceptable limits as prescribed by A-II Class limits by MPCB and BIS:10500-2012. All the water samples were colourless and odourless.

C. Pictures taken during visit to tributaries meeting river Godavari



Waldevi River near Vihitgaon



Confluence of Waldevi and Darna River



**Darna River at Palase Bridge and
Outlet of Chehedhi STP**



Confluence of Darna and Godavari River



**Confluence of Nasardi and
Godavari River**



**Nasardi River Near Hare Krishna Road
Besides Samaj Kalyan Office**

Table 3.8: Analytical Results for Tributaries Samples meeting River Godavari, Nashik (Post Monsoon Season)

Sr.	Parameters	TR1	TR2	TR3	TR4	TR5	TR6	TR7	TR8	TR9	TR10	TR11	TR12	BIS 10500: 2012		MPCB A-II Class Limits
														Acceptable	Permissible	
Physical & Inorganic parameters																
1.	Ambient Temperature	30	29	29	29	29	29	29	29	30	30	30	24			
2.	pH	7.3	7.1	7.5	7.5	7.1	7.0	7.1	7.1	7.1	7.2	7.2	6.8	6.5-8.5	NR	6.5-8.5
3.	Electrical Conductivity	739	801	680	714	558	616	536	502	486	583	703	324	--	--	--
4.	Total Dissolved Solids	443	481	392	428	335	370	322	300	292	350	422	195	500	2000	--
5.	Total Alkalinity as CaCO ₃	274	270	227	278	260	260	266	189	110	90	228	123	200	600	--
6.	Sulphates as SO ₄	12	33	19	28	33	54	43	29	17	18	38	16	200	400	400
7.	Nitrates as NO ₃	BDL	BDL	BDL	BDL	BDL	BDL	BDL	BDL	BDL	BDL	BDL	BDL	45	NR	45

Note: Minimum Detectable Limit For parameters tested are as under (PO₄-0.05, BOD-1.0, COD-5.0, NH₃-N-0.2)

All samples are colourless and odourless.

Values except Temp, EC expressed as mg/l and microbial CFU/100 ml

DO- Dissolved Oxygen, BOD- Biochemical Oxygen Demand, TC- Total Coilforms, EC- E.coli, BDL- Below Detectable Limit

Table 3.8 (Contd.) : Analytical Results for Tributaries Samples for River Godavari, Nashik (Post Monsoon Season)

Sr.	Parameters	TR1	TR2	TR3	TR4	TR5	TR6	TR7	TR8	TR9	TR10	TR11	TR12	BIS 10500: 2012		MPCB A-11 Class Limits
														Acceptable	Permissible	
Organic & Nutrient parameters																
8.	Ammonical Nitrogen as NH ₃ -N	2.9	3.5	2.8	3.1	3.2	2.0	2.8	2.5	2.1	0.3	4.9	3.5	--	--	1.5
9.	Total Phosphate as PO ₄ -P	1.02	0.86	0.9	1.3	0.6	0.67	0.6	0.48	0.41	BDL	1.2	0.37	--	--	--
10.	DO	2.8	4.8	6.0	5.1	6.9	8.0	6.7	2.6	2.7	0.5	3.3	6.3	--	--	
11.	BOD	10.5	5.0	5.8	7.0	4.8	3.0	BDL	9.8	12.5	20.0	17.2	3.0	--	--	5.0 or below 5.0

Note: Minimum Detectable Limit For parameters tested are as under (PO₄-0.05, BOD-1.0, COD-5.0, NH₃-N-0.2)

All samples are colourless and odourless.

Values except Temp, EC expressed as mg/l and microbial CFU/100 ml

DO- Dissolved Oxygen, BOD-

Biochemical Oxygen Demand, TC- Total Coliforms, EC- E.coli, BDL- Below Detectable Limit

Inorganic: Variation in conductivity is observed from Upstream of Nasardi towards Nasardi river, while the Total Dissolved Solids [TDS] appear to be in the range as prescribed by BIS:10500-2012.

The Total Alkalinity is observed to be exceeding the acceptable limits but within the permissible limits of BIS:10500- 2012 at Nasardi river, its upstream and downstream and also at Darna and waldevi river at various points. Sulphates appear to be in low range while nitrates are insignificant with mostly below the minimum detectable limit.

Organic & Nutrient: At temperature between 30°C-34°C, the dissolved oxygen was observed to vary between 0.5- 6.9 mg/L with the lowest DO at observed to be at Darna River over Palase bridge. Highest DO was observed to be at Waldevi River at Vihitgaon.

The Biochemical Oxygen Demand [BOD] of the samples was observed to be above the permissible limits of A-II class limits by MPCB at Palase bridge at Darna river, Nasardi River, Jakhori Bridge over Darna and Darna-Godavari confluence which indicates presence of organic contaminants. The BOD was 4 times of the prescribed standard value at Darna river near Palase bridge.

Ammonical nitrogen levels are observed to be exceeding the permissible limits as mentioned by A-II class limits by MPCB. Presence of ammonia in higher concentration indicates pollution due to sewage/ humans. High levels of ammonia are undesirable since they impart odour to water and make it unfit for drinking purposes.

Thus the analytical results for tributaries joining river Godavari within the study area, are by and large, meeting the Standards of Drinking water as per IS:10500-2012 as well as Water Quality Standards for 'Best Designated usages' A-II class by MPCB. However of all the parameters, BOD is observed to be higher at many places.

3.5 Evaluation of Sewage Treatment Plants

The information on the existing and proposed STPs has been provided by NMC, Sewerage Department and the same is appended in **Annexure 12**. The STPs which were functional during the study period were evaluated for engineering performance as well as quality performance.

3.5.1 Engineering Evaluation

a) 78 MLD Tapovan Plant with UASB Technology

The evaluation for Tapovan STP with UASB technology was done on the basis of following design parameters. Data for pre and post monsoon seasons during 2013- 2014 is considered. Following table depicts the calculated design parameters as against the standard limit suggested for the same by CPHEEO.

Engineering Evaluation of Tapovan UASB Reactor

Sr. No.	Parameter	Post Monsoon (November)	Pre Monsoon March	CPHEEO Standards
1	HRT (hrs)	8.84	9.08	6-12 hr
2	OLR (kg COD/m ³ day)	0.63	0.66	1-2 kg COD/m ³ day
3	Upflow velocity (m/hr)	0.55	0.54	*0.8-1m/hr

**The standard for Upflow Velocity obtained from a book titled "Waste water Engineering" by Metcalf & Eddy, 4th edition*

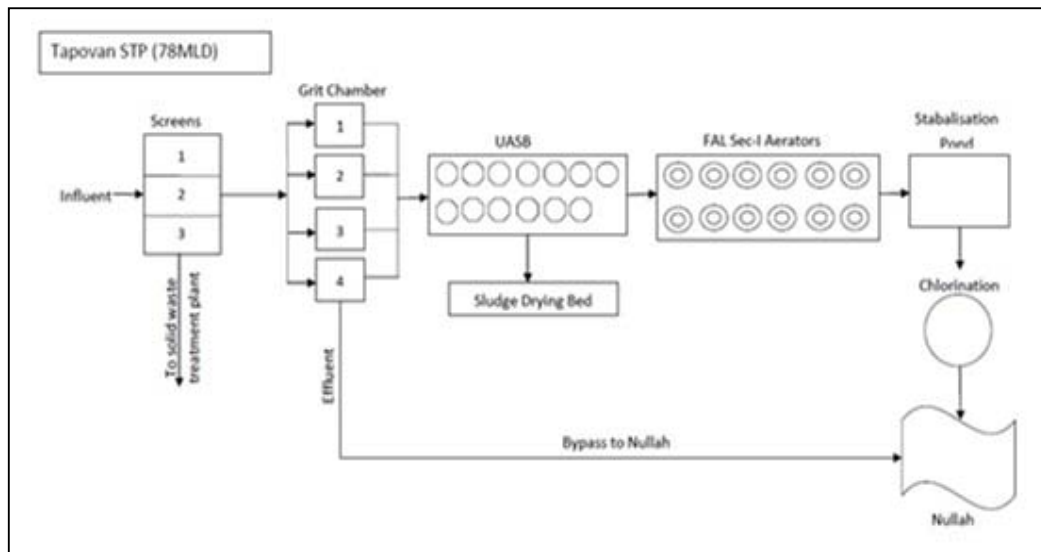

Schematics of Tapovan STP

Observations

1. The Hydraulic retention time for Pre monsoon and Post Monsoon season obtained was in the range of 6-12hrs. The marginal variation was due to variation in flow recorded at the plant. The in pre monsoon was 74 MLD for the selected plant and 76 for Post monsoon.
2. Organic loading rate value prescribed in CPHEEO manual should be in range of 1-2 kg COD/m³d. However the calculated OLR is below standard value. This is because of low concentration of influent COD. The domestic waste water conveyed through the sewerage network is the overflow of the septic tanks which minimizes the strength of the waste at source.
3. The Upflow velocity of UASB for the pre monsoon and post monsoon season was 0.54 m/hr and 0.55m/hr, which is less than the prescribed standard limit
4. Based on the COD values and formula stipulated in Metcalf and Eddy, Methane generation in month of November is expected to be in the range of 166 to 275 m³/d which accounts to energy production up to 8.71x10⁶ kJ/d.
5. According to NMC data, there are two biogas engines of 85 kWh (10.625 kW) each. The power generation expected from the calculation is 63 to 100 kW. One biogas engine can work for 6 to 9.5 hours from the power generated by methane in one hour. Hence the energy produced by the methane will be more than enough for running these engines.

b) Activated Sludge Process at Panchak STP

Based on the design details, the following engineering analysis is carried out for the month of June 2014. The average flow considered is 6.15 MLD as per the data provided by NMC.

Primary Sedimentation Tank

Components	Overflow rate m ³ /day/ m ²		Detention time (hr)	
	Avg.	Peak	Avg.	Peak
Primary Sedimentation	26.43	52.86	2.73	1.36
CPHEEO	25-35	50-60	2-2.5	-

Secondary Sedimentation Tank

Components	Overflow rate m ³ /day/ m ²		Detention time	
	Avg.	Peak	Avg.	Peak
Secondary Sedimentation	19.99	39.97	2.94	1.47
*CPHEEO	15-35	40-50	1.5-2	

Observations:

1. The overflow rate calculated for PST and SST is observed within range according to the CPHEEEEO Manual.
2. In case of PST the detention time is observed 2.73hrs which exceeds the consent range as mentioned in the CPHEEEEO manual. The increased detention time is due to low flow (18%) higher detention time affects the settling efficiency. Similar observation is recorded in case of SST; also it should be noted that longer detention time in secondary settling tank results in denitrification and the prime function of the settling tank will not be achieved in this case.

3.5.2 Performance Evaluation Based on Quality

The four STPs at Trimbak, Tapovan, Panchak and Chehadi were evaluated for its chemical performance. The analytical results and observations are presented below:

a) Trimbak STP –MBBR

Month	Influent			Outlet of MBBR*		
	BOD	COD	TSS	BOD	COD	TSS
April 2014	167	440	218	80	310	87

**The plant was re-commissioned and not fully stabilized.*

The effluent is applied on land and not discharged in any water body.

Observations : The analytical results of Trimbak STP indicates that the BOD of raw sewage was 167 mg/L which was reduced to 80 mg/L in MBBR with a reduction of 52%. The plant was out of operation for servicing and recently commissioned and hence the performance was not upto the mark.

b) Tapovan STP -UASB Technology

Month	Influent			Outlet of UASB			Effluent from FAL			Final Output		
	BOD	COD	TSS	BOD	COD	TSS	BOD	COD	TSS	BOD	COD	TSS
September 2013	95	244	148	46	141	58	26	82	32	18	55	20
November 2013	91	230	155	27	115	45	18	38	25	7	30	15
March 2014	82	250	152	32	134	50	23	86	28	15	58	18

Observations: The analytical results of Tapovan STP indicate that the BOD of raw sewage is quite low and ranged from 82 to 95 mg/L. It was reduced to 27 to 46 mg/L in UASB with a percent reduction of 52 to 70%. The BOD in effluent from FAL ranged from 18 to 26 mg/L indicating a reduction of 28 to 43% and that in the final effluent it ranged from 7 to 18mg/L, thereby indicating 31 to 61 % reduction. The final effluent had BOD always less than the earlier consent value of 30 mg/L. The overall reduction in BOD ranged from 81 to 92 percent which is quite satisfactory.

The methane gas production is adequate to run two biogas engines for eight hours. These biogas engines are used to operate aerators.

c) Panchak STP- ASP Technology

Month	Influent			Outlet of ASP			Effluent from ASP		
	BOD	COD	TSS	BOD	COD	TSS	BOD	COD	TSS
September, 2013	102	234	109	42	110	87	21	46	45

Observations

The analytical results of Panchak STP indicates that the BOD of raw sewage was 102 mg/L which was reduced to 42 mg/L in ASP indicating 59% reduction and 21mg/L in outlet of FAL thereby indicating 50% reduction from ASP to FAL. The final effluent had BOD always less than the earlier consent value of 30 mg/L. The overall reduction in BOD ranged from 79 percent which is quite satisfactory.

d) Chehadi STP - UASB Technology

Month	Influent			Outlet of UASB			Effluent from FAL			Final Output		
	BOD	COD	TSS	BOD	COD	TSS	BOD	COD	TSS	BOD	COD	TSS
September 2013	64	153	108	14	38	34	12	46	21	10	35	20

Observations : The analytical results of Chehadi STP indicates that the BOD of raw sewage was 64 mg/L which was reduced to 14 mg/L in UASB with 78% reduction, it was further reduced to 12 mg/L in FAL thereby indicating 14% reduction. The final effluent BOD of 10 mg/L indicates 17% BOD reduction. The overall reduction in BOD ranged from 84 percent which is quite satisfactory.

3.5.3 Evaluation of Sewerage System Based on NMC Data (2012-2014)

3.5.3.1 Quantification of Pollution load based on Sewage generation, Collection and Transportation to STPs through Pumping

- Water supply to consumer’s end is 310 mld.
- The expected sewerage generation is will be 248 mld considering 80% generation of sewerage.
- The 100% sewage collection is not achieved.
- As per the pumping data for the year 2014(March), 224 mld of sewage is pumped to the four existing STPs. As the nallas are also diverted to pumping stations, the amount of sewage can exceed in rainy season depending on the rainfall.

- Thus 24 MLD of untreated sewage is not collected and flows through nallas or as ground water seepage after application to agriculture field into the river Godavari.

The information on quantity of flows is based on rated capacity and no actual flow measurements at pumping stations are done.

The quantity of uncollected sewage reaching the river via non point sources is expected to be more since the quantity of sewage pumped is based on the **design capacity** of the pump and number of hours the pump is running per day. The rated capacity decreases as the pumping machinery becomes old. The minimum age of sewerage system and pumping station is considered as at least 10 years on the basis of implementation dates of various schemes under UGD/JnNURM.

- It is assumed that the capacity of the pumps is reduced to 80%. Presuming these considerations more volume of sewage remains uncollected and reaches river Godavari. Thus 44 MLD of sewage will also reach Godavari. (24+44=68 mld)
- The average BOD of sewage is 100 to 125 mg/L. Hence 8500 kg of BOD (125kg/ML) of Organic matter is released into the 19 km stretch of river.
- Even if 50% of untreated sewage is used in agriculture fields, still 4250 kg of BOD will find its way into the river. The natural flow of river is negligible during non monsoon months and hence dilution does not occur. This is a major concern of river pollution.

The quantity of the sewage received at New Ganeshwadi, Takali and Kapila pumping stations discharging sewage at Tapovan STP is almost to its design capacity and many a times exceeding the design value. Hence diversion of Nallas to these pumping stations will overload the system and can lead to the failure. This aspect needs detailed investigation and proper reorganization of flows.

3.5.3.2 Pollution Load Reaching Godavari through Nalla's

As per NEERI's recommendations, the nalla diversion activity was started in March 2014 and completed in May 2014.

- To confirm the efficacy of interception and diversion of nallas, it is recommended to conduct actual flow measurement and "Water Audit" to quantify the exact amount of sewage diverted and going to river.
- Diversion and interception of nallas into the trunk sewers and ultimately to the pumping stations needs critical consideration as three out of five pumping stations are overloaded .
- Efficiency of Nalla diversion adopted should also be critically accessed via increase of flow at the respective pumping stations

- Tracer studies should be adopted to confirm the effectiveness of nalla diversion through intercepting sewers.
- Percolation potential of the agricultural field needs consideration for eventual releases in river
- Reverse/flat gradient and sharp bends observed by GIZ in the sewer trunks needs immediate ratification for avoiding overflows
- Overflow and leakages through manholes either for maintenance or repairs works or deliberately done by farmers should be minimized through more stringent patrolling or monitoring and must be stopped.
- Old pumps with low efficiency should be replaced.

Certain malpractices of deliberate breaking of sewer chambers were observed at no. of locations during the survey. The analytical results of samples collected from these places indicates that it is raw sewage which otherwise would have been taken to STP's via intercepting sewers. Such incidences will deteriorate the river water quality. Proper vigilance of sewerage system and prompt ratification is highly recommended.

3.6 Evaluation of STPs based on Secondary Data

Three STPs which were fully functional during the study period were evaluated for their performance. The fourth STP at Agartakli has been commissioned since February 2014 with limited quantity of flow. The flow data at newly commissioned Agartakli STP for April -May 14 indicates that only about 50% of the design flow is received and hence this plant is not considered for evaluation.

The information on sewage quality at various stages of treatment, provided by NMC is presented in **Table 3.9 to Table 3.10. Annexure 13** provides detailed secondary data for the quality of influent and effluent and outlets for UASB and FAL received for Tapovan (Nov., Dec. 2013, Jan. and Feb. 2014) and Panchak (Jan to Aug 2013).

a) Tapovan : The data at Tapovan indicates that the BOD of raw sewage is quite low and ranged from 92 to 97 mg/L. It was reduced to 42 to 47 mg/L in UASB and 16 to 17mg/L in the final effluent thereby indicating 50 to 54 % reduction. The final effluent had BOD always less than the earlier consent value of 30 mg/L. The more stringent standard of 10 mg/L BOD is not feasible with the current system which is designed for 30 mg/L BOD output. Other parameters like pH, DO, Alkalinity and VFA are well within the normal values.

Table 3.9 : Average Values for Evaluation of STPs*: Tapovan UASB

Month	Avg. Flow (MLD)	Influent			Outlet of UASB			Effluent from FAL			Final Output		
		BOD	COD	TSS	BOD	COD	TSS	BOD	COD	TSS	BOD	COD	TSS
November 2013	134	92	278	148	42	129	40	24	73	32	17	53	16
December 2013	135	92	278	140	44	133	38	26	73	27	17	53	16
January 2014	120	95	285	146	47	142	40	27	80	28	16	53	15
February 2014	131	97	291	148	47	143	49	27	80	35	16	50	17

*Provided by NMC

b) Panchak STP: The technology used is ASP. The plant capacity considered for evaluation is 7.5 mld.

The data indicates that the BOD of raw sewage at Panchak ranged from 88 to 97 mg/L which was reduced to 46 to 54 in ASP and 14 to 20 in the final effluent thereby indicating **45 to 50%** reduction. The final effluent had BOD always less than the earlier consent value of 30 mg/L. The more stringent standard of 10 mg/L BOD is not feasible with the current system which is designed for 30 mg/L BOD output. Other parameters like pH, DO, Alkalinity and VFA are well within the normal

Table 3.10 : Average Values for Evaluation of STPs*: Panchak ASP

Month (2013)	Avg. Flow (MLD)	Influent			Outlet of ASP			Effluent from SST		
		BOD	COD	TSS	BOD	COD	TSS	BOD	COD	TSS
January	7.54	88	268	107	51	155	49	18	52	18
March	7.54	93	283	124	47	142	53	20	59	19
April	7.72	91	279	124	49	153	50	14	52	9
May	7.50	92	283	121	46	144	48	18	56	21
June	7.12	92	282	123	50	149	56	19	59	18
July	7.46	88	275	129	54	157	48	18	56	17
Aug.	7.62	87	272	119	52	160	40	15	49	17

* Provided by NMC

The Tapovan STP was more critically evaluated during three seasons because the plant releases the treated effluent near the holy places and temples and faces severe foam problem. Moreover, a severe foam formation problem is faced within the plant in aeration tank and also in the river when released with a gradient and hence, detailed investigation on reasons for foam formation and remedial measures is carried out. The following section provides information on research on foam formation.

3.6.1 Problems Faced in Effective Functioning of STPs

A) Foam formation : The foam formation problem is faced at almost all installations of UASB in India* (TARE). The parameters responsible for the foam formation are temperature, alkalinity, BOD and presence of filamentous microorganisms.

- The temperature of Nashik city significantly varies in different seasons. The minimum temp. recorded in winter is in the range of 6 to 8°C. The optimum temperature recommended for effective functioning is 20⁰C and above. Provision of insulation to UASB is not economically viable solution.
- The UASB system is recommended with high strength waste and minimum BOD of 300 mg/L and above is expected to give good performance. At Nashik for all most all developed areas, Septic tanks are mandatory and hence the BOD is reduced appreciably. There is no scope of increasing the BOD through co-disposal of high strength industrial biodegradable waster like sugar or distillery/wienary industries. Co –disposal is not recommended because it is difficult to maintain the mixing ratio of two wastes streams all through the year and sugar industries function only for 6 month period from October to March. Stringent monitoring is required if mixing practice is adopted.
- NMC does not have valid data on the number of septic tanks connected to sewer lines and hence assessment cannot be made. The design of a septic tank should be modified to achieve better degradation of organic matter and reduction o solid. The policy decision should be taken for the developing areas which are not yet provided with sewerage lines and STPs. This will reduce the load on the nallas which receive the treated liquid waste through soak pits of septic tanks
- During evaluation of the STP, the effluents were analyzed for the microorganisms responsible for foam formation (Microthrix and Gordonia as reported in the literature). And the results indicated absence of these specific species.
- NEERI investigated the issue of foam formation and two technologies can be adopted to tackle this problem viz. use of eco-friendly non silicon base defoamers or providing polishing treatment like Phytorid.
- The steep slope of discharge pipe at Tapovan is generated huge quantity of foam covering the surface of Godavari river. The slope can be minimize by step disposal or taking the disposal pipe line below the water level of a river. This option is likely to face difficulty during non monsoon months, when adequate flow is not available. Under the circumstance the treated effluent can directly be lifted by M/s. India Bull.

B) Chlorination : The disinfection step is adopted to control the coliform group of organisms. Though there is no standard for either coliform or E.coli for the effluent generated at STP, chlorination is practiced as precautionary measure. However the extent of benefits achieved through disinfection are not studied and no records are available. This evaluation study is recommended to decide the dose and efficiency.

- Disinfection of the waste water should also be inspected for possibility of trihalomethane formation potential as these compounds are carcinogenic and toxic.
- Disinfection of sewage with significant NH_3N will lead to formation of chloramines resulting in reduction of disinfecting power. Phytorid technology removes NH_3N and thus will help indirectly for more effective disinfection.
- In absence of minimum dilution and limited assimilative capacity of receiving water body (river Godavari) at Tapovan discharge location, the ammonical nitrogen concentrations are likely to exceed the permissible value for A-II class. River Godavari becomes non perennial during non monsoon months and at many places stagnant pools are observed. Higher ammonical nitrogen also led to water Hyacinth and eutrophication problem.

C) Recycle and Reuse : Attempts have so far, not been made to sale the treated effluent for construction activity or industrial use .

As per census 2011 the population of NMC is 14.87 lakh which is estimated to reach at 48.5 lakh by 2041. With the population quadrupling in next three decades, the net demand for potable water will also increase substantially to 727 MLD. It would be a challenge for NMC to get this much quantity of water reserved from irrigation department as there would be other demands such as agriculture, industry etc. Therefore, as one of the measures of conservation of water, NMC can explore options to recycle waste water and reuse for non-potable use such as gardens, flushing of toilets, process water for industries etc. During the discussion with NMC officials it was informed to NEERI team that the issue of recycle and reuse of treated wastewater has been initiated by Water Resource Department and an agreement has been made for purchase of treated effluent with Ms India Bulls. The administrative formalities are in progress.

D) Compliance to Recent Stringent BOD Standards Stipulated by MPCB

Immediate attention is required to BOD reduction to the recent consent value of 10 mg/L. Application of phytorid as secondary treatment can minimize the BOD when used as polishing step.

3.7 Evaluation of Satpur Industrial Estate

Satpur industrial area has variety of industries covering electroplating, powder coating, basic chemicals, pharmaceuticals and diaries. The list of effluent generating industries evaluated from MIDC, Satpur Taluka is presented in **Table 3.11** (Detailed industries in **Annexure 8**).

Pollution Potential of Electroplating and Powder coating small scale industries is very significant because the effluent generated from electroplating industries mainly contain heavy metals like Cu, Cr, Zn, Ni etc depending upon the metal used for electroplating. These heavy metal bearing wastewaters are of considerable concern as they are non- biodegradable. Only 30 to 40 % of all metals used in plating processes are effectively utilized i.e. plated on the articles. The remaining contaminates the rinse waters during the plating process when the plated objects are rinsed upon removal from the plating bath.

The Satpur area does not possess Common Effluent treatment Plant. Hence most of the industries in Satpur MIDC area have their own ETPs. According to MPCB, the consent is not granted to any industries without construction of ETPs. The most common method used in ETPs for the treatment of electroplating effluents is pH correction followed by settling. The pH correction is achieved by addition of chemicals like caustic soda, lime etc. It is the most economic method used for the treatment of metal bearing industrial effluents. After the treatment with Caustic soda and lime, the wastewater can still contain significant concentration of heavy metals which is not acceptable for discharge to the environment.

Even though the industries claim that the treated effluent is used for gardening and “Zero discharge norms” are adopted, the porosity of the soil needs to be considered as there can be chances of applied effluent percolating down the soil and finally polluting the groundwater resource. According to the MPCB rules, the effluents can be applied on the land at the rate of 20m³/ha. If the quantity of effluent applied on the land exceeds the prescribed limit, the soil can get saturated leading to leachate generation having significant pollutants which ultimately will reach river Godavari. Map of Satpur Industrial Zone with demarcation of industries evaluated is presented in **Annexure 14**.

According to the suggestion by NEERI, 1 MLD CETP has been proposed by MIDC in Satpur area. A land has been allotted by MIDC for construction of CETP in Satpur area. This CETP will mainly receive wastewater from small scale electroplating industries. Though the CETP is proposed, carrying the wastewater to CETP will be a concern as there is no drainage system present in Satpur MIDC area. Hence a provision for carrying wastewater from industries at CETP site also needs to be considered.

Table 3.11 : List of Effluent Generating Industries Evaluated from MIDC, Satpur Tal. & Dist. Nashik

Sr. No.	Industry	Address	Product	Ind. Type	Category	Scale	Total Water Cons. (CMD)	Ind. Wat. Eff. (CMD)	Dom. Wat. Eff. (CMD)	Treatment provided. (Industrial)	Treatment provided (Domestic)
Electroplating											
1	Spectrum Electro-plater	At-Plot no.W-27 MIDC Satpur, Nashik.	Automobile components, Electrical Components (Electroplating job work),	R36 Industry or process involving metal surface treatment or pro	Red	S.S.I	5.00	3.00	1.00	ETP Provided	Septic Tank & Soak Pit
2	Sudha Metal Finishers,	Plot No. W-43, MIDC Satpur, Tal. &Dist. Nashik	Electroplating	R36 Industry or process involving metal surface treatment or pro	Red	S.S.I	11.9	11.2	0.7	ETP provided	Septic Tank & Soak Pit
3	Shree Ganesh Enterprises	F-33, MIDC Satpur, Nashik	Electro Plating Job Work,	R36 Industry or process involving metal surface treatment or pro	Red	S.S.I	6.50	1.00	5.00	ETP Not provided	Septic Tank & Soak Pit
4	Pinnacle Engplast Pvt. Ltd.	A-33/2, MIDC Satpur, Tal & Dist-Nashik	Engineering Components, Electroplating	R36 Industry or process involving metal surface treatment or pro	Red	S.S.I	5.50	1.00	1.00	ETP provided	Septic Tank & Soak Pit

Table 3.11 (Contd.) : List of Effluent Generating Industries Evaluated from MIDC, Satpur Tal. & Dist. Nashik

Sr. No.	Industry	Address	Product	Ind. Type	Cate-gory	Scale	Total Water Cons. (CMD)	Ind. Wat. Eff. (CMD)	Dom. Wat. Eff. (CMD)	Treatment provided. (Industrial)	Treatment provided (Domestic)
Powder and Zinc Plating											
5	Mahan Enterprises	F-78, MIDC Satpur, Nashik	Powder Coating Job Work with phosphating activity	Powder Coating	Red	S.S.I	2.00	0.60	0.80	ETP provided	Septic Tank & Soak Pit
6	Galaxy Metal Finishers	Street No. 19, MIDC Satpur, Nashik	Zinc plating, Phosphating	R36 Industry or process involving metal surface treatment or pro	Red	S.S.I	3.00	1.80	0.50	ETP provided	Septic Tank & Soak Pit
Galvanizing											
7	Jyoti Structures Ltd.	P No.E-60/61 MIDC Area, Satpur, Nashik.	Galvanized Transmission Tower Parts & Other Structure,	R27 Heavy engineering including ship building (With investment o	Red	L.S.I	76.00	18.00	25.00	ETP provided	Septic Tank & Soak Pit
8	Super Metal Industries	Plot No.A-2, NICE, Satpur Tal & Dist. Nashik	Galvanizing Job Work	R27 Heavy engineering including ship building (With investment o	Red	SSI	5.5	1.8	1	ETP provided	Septic Tank & Soak Pit
Ferrous and Nonferrous											
9	Perfect Circle India Ltd.	Plot No. E-34, MIDC Satpur, Nashik	Piston Ring Castings, Shims & Plates Casting	R21 Ferrous and Non ferrous metal extraction involving different	Red	L.S.I	188.00	5.00	30.00	ETP provided	STP

Table 3.11 (Contd.) : List of Effluent Generating Industries Evaluated from MIDC, Satpur Tal. & Dist. Nashik

Sr. No.	Industry	Address	Product	Ind. Type	Cate-gory	Scale	Total Water Cons. (CMD)	Ind. Wat. Eff. (CMD)	Dom. Wat. Eff. (CMD)	Treatment provided. (Industrial)	Treatment provided (Domestic)
Basic Chemicals and Electro Chemicals and its Derivatives											
10	Spak Orgochem (India) Pvt Ltd.	Plot.no.H-8, MIDC, Satpur Tal. & Dist. Nashik	Organic Surfactants, Organic Esters	R05 Basic Chemicals and electro chemicals and its derivatives	Red	S.S.I	21.00	10.70	3.00	ETP provided	Septic Tank & Soak Pit
Pharmaceutical Formulation											
11	Vital Healthcare Pvt. Ltd.	Plot No H-10, MIDC Satpur Tal & Dist. Nashik	pharmaceutical formulation	O50pharmaceutial formulation	Orange	SSI	17.5	2	7.2	ETP provided	STP
Milk and Dairy											
12	Shrirang Kisanlal Sarda	Plot No.C-16, NICE, Satpur Tal & Dist. Nashik	Pasteurization Milk Process	R-47 Milk Processing & dairy products.	Red	SSI	6	4	0.5	ETP provided	Septic Tank & Soak Pit

Table 3.11 (Contd.) : List of Effluent Generating Industries Evaluated from MIDC, Satpur Tal. & Dist. Nashik

Sr. No.	Industry	Address	Product	Ind. Type	Category	Scale	Total Water Cons. (CMD)	Ind. Wat. Eff. (CMD)	Dom. Wat. Eff. (CMD)	Treatment provided. (Industrial)	Treatment provided (Domestic)
Tyres and tubes vulcanization/hot retreading											
13	CEAT Limited	82, MIDC Satpur, Tal & Dist-Nashik	Automotive Tyres, Automotive Tubes	O72 Tyres and tubes vulcanization/hot retreading	Red	L.S.I	1,300.00	100.00	300.00	Primary Treatment	STP
Automobile											
14	Mahindra and Mahindra Ltd.	P. No. 89, MIDC Satpur, Tal & Dist-Nashik	Utility vehicles, cars, Light commercial vehicles & their aggregates	R04 Automobiles Manufacturing (integrated facilities)	Red	L.S.I	1,500.00	430.00	400.00	ETP provided	STP
Heavy Engineering including Ship Building											
15	Graphite India Ltd	Plot No. 88, MIDC Indl area, Satpur, Nashik	Baked & Reabaled Electrodes, Graphite Fines/ Carbon ash	R27 Heavy engineering including ship building (With investment	Red	L.S.I	659.00	60.00	27.00	ETP provided	STP

To assess the potential of these industries as a source of pollution, NEERI officials visited some of the industries in Satpur MIDC area. During first visit, samples were collected by MPCB officials.

During the second visit, influents and effluent samples were collected by NEERI team in presence of MPCB. Mainly large scale industries were focused during this visit. During this visit total 11 industries were visited. Out of these 11 industries, samples could be collected from 8 industries. The list of industries visited for evaluation along with the sample code and type of industry, the list is presented in **Table 3.12**.

Table 3.12 : List of Industries Covered for Collection of Samples for Evaluation

Sample Description	Sample Code	Type of Sample	Type of Industry
Electroplating Industries			
Spectrum Electroplater	1	Influent	Small Scale Industry
	2	Effluent	
Sudha Metal Finishers	3	Influent	Small Scale Industry
	4	Effluent	
Shree Ganesh Enterprises	5	Influent	Small Scale Industry
	6	Effluent	
Pinnacle Engplast Pvt. Ltd.	7	Influent	Small Scale Industry
	8	Effluent	
Powder Zinc Coating and Galvanizing Industries			
Mahan Enterprises	9	Influent	Small Scale Industry
	10	Effluent	
Galaxy Metal Finishers	11	Influent	Small Scale Industry
	12	Effluent	
Jyoti Structures Ltd	13	Influent	Medium Scale Industry
	14	Effluent	
Super Metal Industries	15	Influent	Small Scale Industry
	16	Effluent	
Hindustan Electroplaters	17	Influent	Small Scale Industry
	18	Effluent	
Basic Chemicals, Electro Chemicals and its Derivatives & Ferrous and Nonferrous			
Perfect Circle India Ltd. ETP 1	19	Influent	Large Scale Industry
	20	Effluent	
Perfect Circle India Ltd. ETP 2	21	Influent	Large Scale Industry
	22	Effluent	
Spak Orgochem (India) Pvt. Ltd.	23	Influent	Small Scale Industry
	24	Effluent	

**Table 3.12 (Contd.):
List of Industries Covered for Collection of Samples for Evaluation**

Sample Description	Sample Code	Type of Sample	Type of Industry
Pharmaceutical Formulation, Tyres and Tubes Vulcanization/hot Retreading, Automobile, Heavy Engineering including Ship Building			
Vital Healthcare Pvt. Ltd.	25	Influent	Small Scale Industry
	26	Effluent	
CEAT Limited	27	Influent	Large Scale Industry
	28	Effluent	
Mahindra and Mahindra Ltd.	29	Influent	Large Scale Industry
	30	Effluent	
Graphite India Ltd	32	Influent	Large Scale Industry
	33	Effluent	
Dairy Industry			
Shrirang Kisanlal Sarda Inlet	34	Influent	Small Scale Industry
	35	Effluent	

The samples from Taparia Tools Ltd. and Glenmark Pharmaceutical Ltd. Were collected and analyzed by MPCB and the results are presented in **Annexure 15**.

The analytical results of industrial samples are presented in **Table 3.13**. The results were compared with the standards prescribed by CPCB for general effluent discharge, electroplating, inorganic chemicals, dairy and CETP are presented in **Annexure 16**.

Observations

During the NEERI's visit to Satpur MIDC area, total 15 industries were visited. These industries included 4 electroplating industries, 5 powder coating industries, 3 basic chemical industries, 1 pharmaceuticals, 1 automobile, 1 tyre tube and one dairy industry.

1. Electroplating Industries, Powder Zinc Coating and Galvanizing Industries

Many of the industries have ETP operated as a batch process. The treatment for effluent from electroplating mainly includes pH correction by addition of caustic soda or lime. The effluent quality was assessed by comparing the Discharge Standards prescribed by CPCB for Electroplating Industries.

Table 3.13 : Analytical Results of Heavy Metals of Industrial Samples in Nashik (Dated : April-May, 2014)

Parameters	Units	1	2	3	4	5	6	7	8	Discharge standards for Electroplating industries by CPCB
Electroplating Industries										
Sample type	-	Inlet	Outlet	Inlet	Outlet	Inlet	Outlet	Inlet	Outlet	
Physical Parameters										
pH		0.9	6.5	1.6	2.6	1.1	1.9	5.2	5.6	6-9
Inorganic Parameters										
Total Suspended Solids	mg/L	110	100	140	100	280	310	180	200	100
Oil & Grease	mg/L	80	20	70	50	180	170	20	10	10
Heavy Metals										
Cadmium	mg/L	0.06	BDL	0.02	0.01	0.12	0.03	0.01	0.01	2
Nickel	mg/L	23.97	0.23	11.26	6.16	2.80	2.61	BDL	BDL	3
Zinc	mg/L	14.05	1.55	9.37	7.33	10.24	10.10	2.27	4.30	5
Total Chromium	mg/L	7.63	0.02	1.20	0.13	43.31	33.58	7.54	4.75	2
Copper	mg/L	41.09	0.90	40.20	24.14	14.21	32.12	0.10	0.12	3
Lead	mg/L	0.77	BDL	5.55	0.29	2.58	0.28	BDL	BDL	0.1
Iron	mg/L	53.17	1.69	34.66	11.35	41.52	32.36	9.97	6.82	3
Organic & Nutrient Parameters										
NH ₃ -N	mg/L	8.6	2.7	3.3	0.8	16.2	7.6	0.1	0.2	50

Table 3.13 (Contd.) : Analytical Results of Heavy Metals of Industrial Samples in Nashik (Dated : April-May, 2014)

Parameters	Units	9	10	11	12	13	14	15	16	17	18	Discharge standards for Electroplating industries by CPCB
Powder Zinc Coating and Galvanizing Industries												
Sample type	-	Inlet	Outlet	Inlet	Outlet	Inlet	Outlet	Inlet	Outlet	Inlet	Outlet	
Physical Parameters												
pH		1.9	2.6	5.9	6	3	7	0.6	6.9	5.2	5.7	6-9
Inorganic Parameters												
Total Suspended Solids	mg/L	180	120	50	20	12	6	40	14	170	90	100
Oil & Grease	mg/L	10	5	20	10	10	10	15	10	50	20	10
Heavy Metals												
Cadmium	mg/L	0.04	0.06	0.01	BDL	0.02	0.05	0.01	0.01	0.01	0.01	2
Nickel	mg/L	7.65	8.33	0.12	0.06	0.09	0.07	1.43	0.05	0.06	0.02	3
Zinc	mg/L	9.82	10.03	2.29	1.15	13.03	11.06	15.32	13.72	9.66	1.59	5
Total Chromium	mg/L	7.44	5.16	0.16	0.12	0.02	BDL	2.564	BDL	27.89	0.08	2
Copper	mg/L	1.41	1.29	0.06	0.05	0.07	0.04	1.71	0.15	0.06	0.05	3
Lead	mg/L	4.24	1.00	BDL	BDL	BDL	BDL	1.68	BDL	BDL	BDL	0.1
Iron	mg/L	41.63	41.70	0.51	1.90	46.49	2.95	51.18	16.52	34.94	4.66	3
Organic & Nutrient Parameters												
NH ₃ -N	mg/L	5.2	0.6	BDL	BDL	5.8	1.0	1.1	0.6	6.5	BDL	50

Table 3.13 (Contd..) : Analytical Results of Heavy Metals of Industrial Samples in Nashik (Dated : April-May, 2014)

Parameters	Units	19	20	21	22	23	24	Discharge standards of inorganic Chemical industries, CPCB
Basic Chemicals and Electro Chemicals and Its Derivatives & Ferrous and Nonferrous								
Sample type	-	Inlet	Outlet	Inlet	Outlet	Inlet	Outlet	
Physical Parameters								
pH		5.9	6.1	6	6.1	4.8	6.5	6-8.5
Inorganic Parameters								
Total Suspended Solids	mg/L	160	130	110	90	26	24	30
Oil & Grease	mg/L	50	30	10	10	20	10	10
Heavy Metals								
Cadmium	mg/L	0.01	0.01	0.05	0.02	BDL	0.01	0.2
Nickel	mg/L	1.41	BDL	0.41	0.08	0.27	0.02	2
Zinc	mg/L	3.66	1.47	1.02	0.90	2.00	BDL	5
Total Chromium	mg/L	BDL	BDL	40.70	7.57	0.29	BDL	2
Copper	mg/L	0.16	0.04	0.21	0.12	0.07	0.04	2
Lead	mg/L	0.12	BDL	0.46	0.10	BDL	BDL	0.1
Iron	mg/L	20.87	0.11	1.16	0.80	2.74	0.18	2
Organic & Nutrient Parameters								
NH ₃ -N	mg/L	4.72	BDL	3.6	2.3	38.8	6.1	50

Table 3.13 (Contd..) : Analytical Results of Heavy Metals of Industrial Samples in Nashik (Dated : April-May, 2014)

Parameters	Units	25	26	27	28	29	30	31	32	33	Discharge standards for by CPCB for Inland surface water
Pharmaceutical Formulation, Tyres and Tubes Vulcanization/hot Retreading, Automobile, Heavy Engineering Including Ship Building											
Sample type	-	Inlet	Outlet	Inlet	Outlet	Inlet	Outlet	STP Inlet	Inlet	Outlet	
Physical Parameters											
pH		7	6.9	5.7	7.4	6.5	7.7	7.0	7.2	7.4	5.5-9
Inorganic Parameters											
Total Suspended Solids	mg/L	46	22	117	97	50	27	18	90	38	100
Oil & Grease	mg/L	20	10	20	10	40	30	20	10	10	10
Heavy Metals											
Cadmium	mg/L	0.02	0.01	0.01	0.01	BDL	0.02	BDL	0.02	0.01	2
Nickel	mg/L	0.04	0.04	0.10	0.11	2.91	0.23	BDL	0.10	0.02	3
Zinc	mg/L	3.89	0.42	2.63	0.39	1.60	1.49	BDL	2.18	1.33	5
Total Chromium	mg/L	BDL	BDL	BDL	BDL	0.09	BDL	BDL	BDL	BDL	2
Copper	mg/L	0.21	0.03	0.14	0.26	0.09	0.05	BDL	0.40	0.06	3
Lead	mg/L	BDL	BDL	BDL	BDL	BDL	BDL	BDL	0.11	BDL	0.1
Iron	mg/L	5.23	1.20	32.88	3.81	3.50	2.90	BDL	34.67	3.74	3
Manganese	mg/L	0.40	0.13	0.91	0.26	20.29	0.69	0.08	1.44	0.24	2
Organic & Nutrient Parameters											
NH ₃ -N	mg/L	0.05	1.0	8.3	2.0	5.2	1.9	8.5	1.2	1.2	50
BOD	mg/L							160			30
COD	mg/L							500			250

Table 3.13 (Contd..) : Analytical Results of Heavy Metals of Industrial Samples in Nashik (Dated : April-May, 2014)

Parameters	Units	34	35	Discharge standards for Dairy industries by CPCB
Dairy Industry				
Sample type	-	Inlet	Outlet	
Physical Parameters				
pH		5.4	5.8	6.5-8.5
Inorganic Parameters				
Total Suspended Solids	mg/L	170	120	150
Oil & Grease	mg/L	20	20	10
Organic & Nutrient Parameters				
BOD	mg/L	650	360	100

- Physical Parameters:** The treated effluents from electroplating industries show pH in the low ranges at the outlet. Industrial samples of Sudha Metal Finishers, Shree Ganesh Enterprises, Pinnacle Engplast Pvt Ltd, show very low pH values. The pH is very important for determining efficiency of the treatment as the neutralization step precipitates the heavy metals effectively to the expected value. The outlets of these industrial samples need to be properly neutralized before disposal. The proper neutralization will result in removal of metal contamination. Low pH upon entering the aquatic ecosystem will also impact the natural equilibrium of the water body.
- Inorganic Parameters:** The Total Suspended Solids [T.S.S] of the industrial effluents had exceeded guideline values for Shree Ganesh and Pinnacle Engplast Pvt Ltd. indicating that inefficient removal of suspended matter occurs in the ETP of the industry. Either the neutralization is not adequate or settling time provided needs to be extended. The oil and Grease in the industrial effluents were found to be within the prescribed limits by CPCB. However few effluents like those of Sudha Metal Finishers, Shree Ganesh Enterprises show values higher than the standard limit of 10mg/L.
- Heavy Metals:** The effluent quality from three industries namely Sudha Metal Finishers, Shree Ganesh Enterprises, Mahan Enterprise were found to be exceeding the prescribed standards in terms of heavy metals for Nickel, Zinc, Total Chromium, Copper, lead, iron. The effluent from Pinnacle Engplast Pvt Ltd exceeds the effluent discharge standards for Total Chromium and iron. While high concentrations of iron and zinc are observed in the effluent of Supermetal industries. This could be the acquired iron present in the industrial wastewater. Presence of heavy metal in effluents can allow them to enter in the water bodies causing no. of hazards like liver damage, nausea, paralysis, tumor etc upon entering the biological system of living organism. Thus effective removal of heavy metals must be done for all effluents discharge from the electroplating industries

2. Basic Chemicals and Electro Chemicals and its Derivatives, & Ferrous and Nonferrous

The effluent from these industries was compared with the CPCB Discharge Standards for Inorganic Chemical Industry. The treatment for effluent from these industries mainly includes pH correction by addition of caustic soda or lime.

The effluent characteristics from most of the industries complied prescribed CPCB standards. Although the effluents are applied on land, there can be a possibility of the metals leaching out and eventually join groundwater or other water body which will pollute the river.

3. Pharmaceutical Formulation, Tyres and Tubes Vulcanization/hot Retreading, Automobile, Heavy Engineering Including Ship Building

The effluents characteristics from these industries have been compared with the “General Discharge Standards by CPCB for Inland Surface Water since no specific industry specific standards are available.

The effluents characteristics from these industries indicate that values within the permissible limits. While the iron concentration for two industries was slightly above the limits, all other heavy metals are well within lower ranges.

Presence of Iron does not pose critical problem because as it gets diluted with pH of neutral of alkaline range, the ferrous iron is converted into insoluble ferric form which settles in the sediment. Moreover, it is present in abundance in soil and hence many a times termed as “Acquired iron”.

4. Dairy Industry

The results of these are compared with the prescribed Standards for Dairy by CPCB.

Physical Parameters: The effluent from Shri Rang Sarda dairy was observed to have low pH of 5.8 as against the range of 6.5-8.5. The Total Suspended Solids [T.S.S] were observed to be within the standard limit. Oil and grease concentration was found to be slightly higher than the limits of 10 mg/L for effluents.

Organic & Nutrient Parameters: The Biological Oxygen Demand [B.O.D] of the effluent was observed to be higher than the limit of 100 mg/L as mentioned by Dairy Standards of CPCB. Higher organic content could be attributed to the presence various constituents of milk. Effluent with higher organic content must be treated effectively before releasing in the environment.

3.7.1 Recommendations

- There is an urgent need for installation of a CETP for small scale water polluting industries
- The “Zero Discharge criteria” stipulated by MPCB needs critical evaluation as “Post project monitoring activity” with respect to soil conditions and possibility of seepage out of sub soil water having these contaminants.
- It should be made mandatory for all small scale industries to treat their waste into CETP once constructed.
- Carrying the industrial waste to CETP will incur additional water requirement for participating the industry for gardening.

3.8 Solid Waste

The domestic solid waste management system located at Pathardi about 15 Km south of Nashik city has complete solid waste management system covering segregation of plastic, composting, leachate treatment, refuse driven fuel manufacturing facility and furnace for biomedical treatment facility and disposal of dead animal. Multiple facilities are established within the plant for solid waste treatment and disposal. The features of solid waste management system in Nashik are summarized in a following **Figure 3.2**.

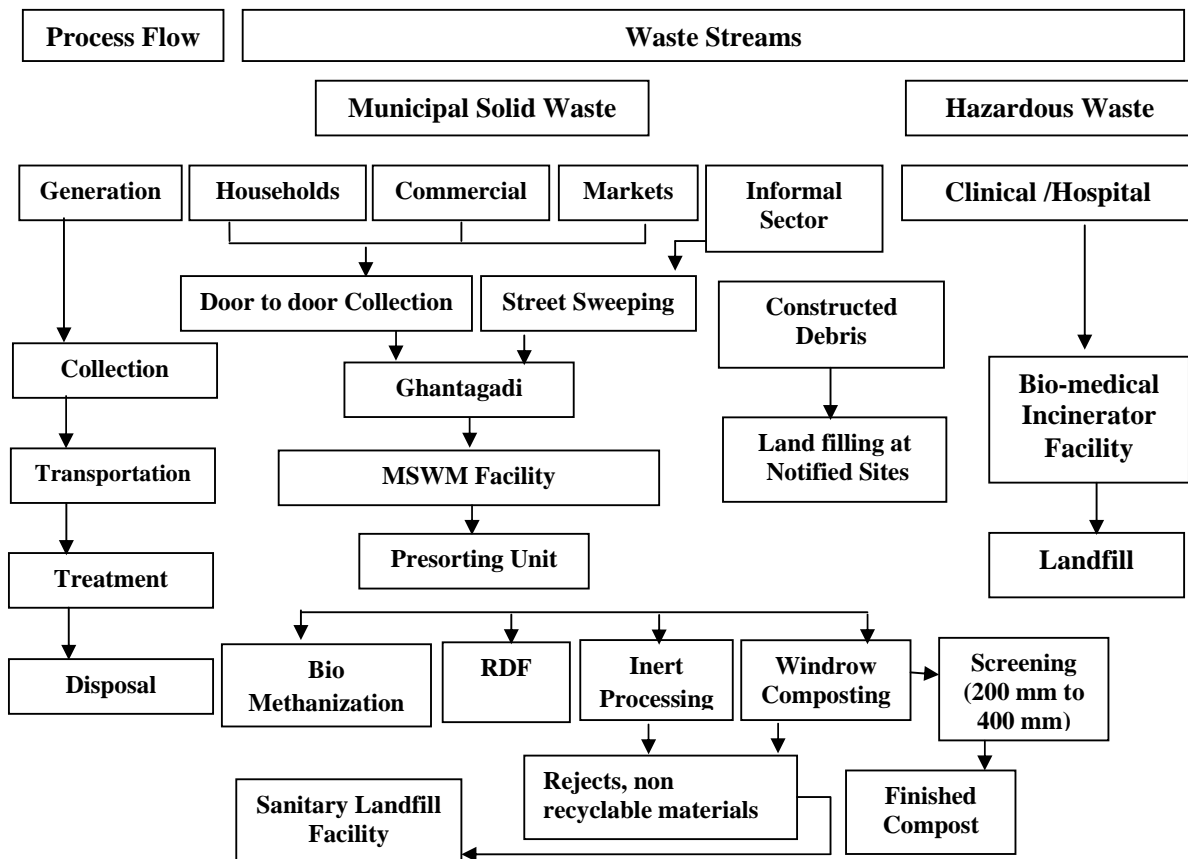

Figure 3.2 : The Solid Waste Management Scheme of Nashik as Indicated in CDP 2012

Special features for collection of domestic solid waste from Nashik city are :

- There are no dust bin placed by the side of the roads in the residential localities which otherwise can create insanitary conditions and odor problem if not collected properly.
- The garbage is collected from the city with the help of vehicles named “Ghantagadi”.
- Provision of number of Nirmalya kalash for collection of Nirmalya at the banks of Godavari River is made as a segregation step which also protects the sentiments of the devotees.
- Trolleys are also provided for collection of Nirmalya at Gharpure ghat
- An Incinerator is provided with a facility which also caters the need for burning the dead animals

3.8.1 Collection of Municipal Solid Waste

Nashik city has door to door collection system for domestic Solid waste. The solid waste collection in the city is about 95%. Absence of public dustbins in the city reduces the chances of accumulation of solid waste in the city. Solid waste is collected from 2.9 lakh households located in 108 wards of the city through Ghanta Gadis. Total 160 vehicles are provided for the solid waste collection. Every vehicle is accompanied with 3 persons. As soon as the waste is collected, persons accompanying the vehicles start on site segregation of the waste and the recyclable material are sold off to the dealers in the market. Separate trucks have been arranged for carrying waste from Bhaji market. The information of the system adopted for collection of domestic solid waste is presented in the **Table 3.14**.

Table 3.14 : Details of the Domestic Solid Waste collection System in Nashik

Particulars	Unit	quantity
Generation	MT	393
Collection	MT	363(About 92%)
Vehicles	No.	160
Wards covered	No.	108
Size of Disposal site	acre	84

The quarterly data indicating zone wise collection of domestic solid waste during the year 2010 - 2011 is presented in the following **Table 3.15**.

The vehicles engaged for solid waste collection carry the waste to Compost site located at Pathardi which is outside the boundary of Nashik city.

Table 3.15 : Information on Quantity of Domestic Solid Waste Collected from Different Zones by “Door to Door” Scheme

Areas	Q1	Q2	Q3	Q4
	Apr-June 2010	July-Sept 2010	Oct-Dec 2010	Jan-Mar 2011
Quantity of Solid Waste Collected (Metric tons)				
Panchvati	1636-1917	1331-2031	1783-1994	1499-1741
Nashik Rd	1679-1940	1496-2191	1883-2192	1623-1781
Nashik(E)	1411-1602	1391-2231	1997-2261	1590-1880
CIDCO	1537-1741	1176-1838	1698-1939	1498-1676
Satpur	888-1005	792-1115	962-1059	817-920
Nashik (W)	987-1123	863-1330	1255-1455	1072-1141

Q = Quarters

3.8.2 Characterization and Treatment of Solid Waste

The Municipal domestic solid waste generated and collected has the following composition (**Table 3.16**).

Table 3.16 : Characterization of Municipal Solid Waste (MSW) at Nashik

Items	Quantity (%)
Plastic	1.0
Coconut shell	1.0
Paper and Thermocol Material & Others	1.0
Gunny Bags and Cotton rags	0.6
Glass, Metals	0.6
Lather, Shoe, Chappal	0.6
Tree Cutting, Garden Waste	5.0
Tyre, Tube, Rubber	0.2
Sand, Debris	20.0
Water/ Humidity	30.0
Organic Matter	40.0

Source : ESR, 2012

Basically MSW can be categorized in four groups viz. compostable, recyclable, inerts and moisture. The ranges observed are summarized in **Table 3.17**. Moisture is an important parameter as it makes the material heavy for transportation and generates more leachate during treatment. According to this classification, the MSW at Nashik has only 30% of moisture which indicates favorable conditions for transportation and leachate generation. Similarly the values for Recyclable are very low which confirm the segregation of such items at source and recyclable material does not reach the plant for processing. Other values are fairly comparable and fall within the range reported for various cities in India.

Table 3.17 : Composition of MSW in Nashik

Composition Group	Ranges Reported for Cities in India (%)	Values Observed in Nashik (%)
Compostable	46 -51	46
Recyclable	16 -23	4
Inerts	28 -33	20
Moisture	50 -53	30

3.8.3 Methodology of MSW Collection

Ghantagadis transfer the garbage from the city to the Compost site. The solid waste material received is weighed at the weighing bridge and daily records are maintained. Weekly 6 tones of plastic waste are collected by the rag pickers who sold it to “Agro Pipes Company” located at Malegaon. The company utilizes this plastic waste for making pipes. The proposal has been prepared for reusing the plastic for production of oil at the plant proposed to be constructed at Sinner. The financial transactions for the collection and sell of plastics are done by the rag pickers association.

Amount of Plastic and Tyres Segregated and Sold Off for the Year : 2010-11

Product Name	Q1	Q2	Q3	Q4
	Apr-June 2010	July-Sept 2010	Oct-Dec 2010	Jan-Mar 2011
Plastic (Kg)	2160-10305	1700-14130	740-11910	160-12630
Tires(Kg)	30-1460	35-2180	355-2670	160-570

The Solid waste material after separation of plastics is processed further. The processing scheme mainly includes following units.

Details of the Processing Units Installed at MSW Site at Patherdi

Machinery	Current status
Pre sorting unit	Working
100mm sieve	Working
75mm sieve	Working
16mm sieve	Working
Finishing section	Working
RDF plant	Not Working
Inert	Not Working
0.4MLD leachate treatment plant	Working
Dead animal carcass	Working

The information of the existing MSW Treatment plant along with the photos of various units is presented in **Figure 3.3**.



Figure 3.3 : MSW Treatment Plant and Sanitary Landfill Site at Khat Prakalp, Nashik

a) Presorting Unit (Capacity : 500 MTPD) : Solid waste is segregated in four different categories using mechanical sieves. Rag pickers are officially permitted to segregate and collect the material of their use. Recyclable material like plastic, paper is segregated and is sent for recycling and reuse. Sand, silt is segregated from the solid waste and is sent to inert processing unit. Materials like paper, jute, wood, broken furniture, tree twigs, textiles etc. with combustible fraction and high calorific value is proposed to be sent to RDF unit. Generally, non segregated MSW contains 20 to 30% of waste that can be used for the preparation of RDF. Such materials have moisture content less than 20% and calorific value more than 2000 kcal/Kg.

b) Aerobic Composting Unit : NMC has adopted Windrow composting technique for composting. The solid waste is sprayed with a bioculture for decomposition. 600-800 grams of bicultural is added per ton solid waste. Solid waste collected is kept in composting sheds for 30 days. To maintain the moisture content of the MSW, water or leachate generated at the site is sprayed over the MSW. After completion of composting time it is passed through the sieves of 100, 35 and 16 mm size and sent to the composting refining unit. After composting refining unit, waste is again kept for composting for 15 days. This part of waste is then passed through the sieves of 4mm. The compost obtained is sold off at the rate of 2500/- per M tons as loose. If sold in the packaged form, it is sold at the rate of 3000/- per M tons. NMC has set up a laboratory to analyze garbage and the compost produced for general parameters.

c) Animal Carcass Incinerators: (Capacity: 250 Kg per hr) : Dead animals are incinerated in Animal Carcass Incinerators.

d) Leachate treatment plant: (Capacity: 10 TPD) : In accordance with the Municipal solid waste rules, 2000, leachate is quality monitored. Leachate formed is collected through underground drainage system and treated. The leachate generated at the solid waste management site is treated with the help of a gravel bed and a biodigester. The effluent from biodigester is collected in a tank and is used for gardening and spraying on the heaps of processed compost within the plant.



To check the suitability of leachate for land application, samples were collected by NEERI team during the visit at Compost site at Pathardi on 5th December 2014. In total 4 leachate samples were collected from Compost site and the details of the locations are presented below :

Sample Code	Sample Name	Sample Code	Sample Name
L1	Initial leachate generated	L3	Outlet of biodigester
L2	After pebbles (inlet to Biodigester)	L4	Treated leachate with infiltration content

The collected samples were analyzed for important parameters to find out its suitability for irrigation. The physico chemical characteristics of leachate samples are presented in **Table 3.18**.

Table 3.18 : Characteristics of Leachate Samples at Various Stages of Treatment at MSW Plant, Nashik

	Units	L1	L2	L3	L4
Physical Parameters					
pH		7.7	7.5	7.6	7.5
Colour		Black	Black	Black	Black
Inorganic Parameters					
Conductivity	μS/sec	20660	7815	5780	1427
TDS	mg/L	12396	4689	3468	856
Organic Parameters					
BOD	mg/L	1530	1260	1140	1050
COD	mg/L	8000	6000	6000	4000
Ammonical Nitrogen	mg/L	94.6	87.6	75.5	5.13
Total Nitrogen	mg/L	244	206	166.8	35.1
Total Phosphorus	mg/L	25	17.2	11.7	1.6

e) Inert Processing Unit: (Capacity: 50TPD) : Sand, silt and inorganic material collected from presorting unit is sent and processed in the inert processing unit.

f) Sanitary Landfill Site: Solid waste which cannot be recycled or unused products of the processing units are sent to landfill site. For this purpose, a sanitary landfill in an area of 2 hectare has been developed. The landfill site is lined by 1.5mm HDPE sheet. Landfill site is covered with sand or the inert material. The land fill unit is a secured component of the system.

g) Refuse Derived Fuel Generation: In a world of diminishing resources and increasing needs, each opportunity for the reuse of waste material must be examined. The developing countries rely on wood, dung and fossil fuels to meet their energy needs. With rising demand for fuels in developing countries and supplies reduced, economic growth and individual wellbeing will depend on more efficient use of traditional fuels, better management of natural resources and widespread substitutes for fossil fuels.

RDF can be one such substitute for the conventional non-renewable fuels. It is a combustible fraction of normal household waste where recyclable material is sorted out and which is ground to a homogenous particle size for better handling in different combustion systems. Refuse derived fuels cover a wide range of waste materials, which have been processed to fulfill guidelines, regulatory or industrial specifications mainly to achieve high calorific value. Waste derived fuels include residues from solid waste recycling, industrial waste, sewage sludge, industrial hazardous waste, biomass waste etc. RDF creation from Municipal solid waste involves a process wherein the waste is densified or the physical form is altered and enrichment of its organic matter is done through removal of inorganic matter and moisture.

Another method of production RDF from MSW is preparation of carbonized tablets by addition of malt feed and zeolite as additive. The thermal properties of carbonized pellets can be evaluated with thermal analyzers such as Thermogravimetry, Differential Thermal analysis, Differential scanning calorimetry and calorimeter. The quantity of RDF produced per ton of MSW varies depending on the type of collection, treatment process and quality requirement..The calorific value of RDF also depends on the composition of the Municipal solid waste. The following options for the utilization and conversion of RDF from MSW to energy could be used:

- On-site in an integrated thermal conversion device, which could include grate or fluidized bed combustion, gasification or pyrolysis;
- Off-site at a remote facility employing grate or fluidized bed combustion, gasification or pyrolysis;
- Co-combustion in coal fired boilers;
- Co-incineration in cement kilns;
- Co-gasification with coal or biomass.

The Calorific Value of RDF: Calorific value is the amount of heat produced by combustion of unit mass of fuel and is generally expressed in terms of joules/Kg or Cal/Kg. To check the efficiency of RDF for using as a fuel, the calorific value of generated RDF needs to be estimated and can be compared with the commonly used fuels. The calorific values of commonly and effectively used fuels as reported in IPCC* are mentioned below :

Type of Fuel	Calorific value*(Ranges)	
	KJ/Kg	Kcal/Kg
Wood	14,400-17400	3439- 4155
Charcoal	29600	7069
Lignite Coal	16300	3893
Kerosene	42839	10232

* Intergovernmental Panel of Climate Change Guidelines for National Greenhouse Gas Inventories, 2006

The information reported in literature for RDF produced from recyclable material are presented below:

Typical Fuel Characteristics of RDF Material

Dry basis (%)	RDF
Volatiles	80.4
C	58
H	7
Calorific value (KCal/Kg)	5473

Refuse Derived Fuel (RDF) Unit Installed at Pathardi: (Capacity: 150 TPD)

The unit has been constructed, installed and trial runs were conducted. Technically the unit is functional but it is not operational on a regular basis because the material suitable for RDF having higher calorific value is not adequate in the solid waste matter received at Pathardi site due to segregation at source in the “Ghantagadi” itself.

Materials having high calorific value like Woody materials, paper products, textiles, jute are collected separately for processing in the RDF unit for generation of fuel pellets. The treatment includes refinement of segregated MSW through material re-combinations, segregation, drying, size reduction, blending and homogenization. This material is further refined for separation of sand, dust, metals, glass etc before shredding. Shredded materials are then converted into pellets. Initial trials were carried out for the productions of RDF but had certain constraints like the calorific value of the product and the clients who will buy this fuel. Currently this RDF unit is not in use due to lack of manpower to operate it.

The Process materials were analyzed for the determination of calorific value to estimate the potential of formation RDF. The calorific value was analyzed with the help of Bomb Calorimeter.

Results of calorific value estimated indicated the value of 2534 (KCal/Kg). This value appears to be average good quality. However people are reluctant to use the fuel prepared from the waste material and hence the probable consumer for this product will be in hotels and in boilers. The cost economic and techno economic evaluation is required before adopting this installed technology.

h) Biomedical Waste: On an average, 2000 kg of Biomedical waste is generated from the hospitals in the city. Nashik Municipal Corporation has taken special efforts to treat biomedical waste in the city. As per Biomedical Waste (M&H) Rules, 1998, Biomedical waste is collected in the specific vehicle and specific colored plastic bags. NMC has appointed one private agency “Water Grace Products Ltd” for collection, treatment and disposal of generated biomedical waste. This company takes fees from the hospitals and clinics for collection and treatment of the biomedical waste. The collected biomedical waste is treated at Common Biomedical waste Management Project near Dwarka, located at Mumbai Agra Highway, Nashik. Treatment system mainly includes

a) Incineration: The incineration system includes a double chambered incineration with receiving chamber, ventury scrubber, cyclone separator, water sprinklers, ID fan and chimney.

b) Autoclaving and Shredding: Ash generated out of incinerators is chemically inert. It is about 5% of the total biomedical waste generated. Treated Biomedical waste is disposed off at Kannamwar Bridge having capacity of 300Kg/h.

3.8.4 Evaluation of the Domestic Solid Waste Management System for the Nashik City

NEERI team visited the plant to evaluate its compliance to the stipulated guidelines. The following observations are made and recommendations suggested for improvement.

- The MSW Treatment plant is in the open space away from the city.
- It is well maintain and no odor problem was noticed.
- Enough space is available for dumping of the MSW for further processing.
- To avoid the spread of plastic or lighter material to nearby areas due to wind, Bamboo trees have been planted at the boundary of solid waste management site at Patherdi.
- Biodegradation processes are carried out in a covered shed.

- Leachate collection system is installed and functioning well. However the efficiency for the removal of BOD and COD needs to be improved if this treated leachate is planned for utilization for agriculture
- The vegetable plants grown near the vicinity and fed by treated leachate were healthy and bearing fruits
- Residents do not throw articles with high calorific value like paper, wood, material of cellulose origin like diapers, tissue papers and segregate in their houses for selling. The workers engaged on Ghantagadi start segregation in the vehicle itself and hence the material with utility for certain byproducts like RDF is reduced.
- Rag pickers are allowed to segregate and collect the recyclable plastic waste. This collected material is sold off in the nearby markets. This has helped in generation of source of livelihood for rag pickers.
- The workers have been provided with masks and hand gloves while handling the solid waste. Hence the safety precautions have been adopted while handling the solid waste.
- RDF unit is not in a working condition due quality of the product and lack of manpower. Hence, more personnel need to be appointed at solid waste management site. The calorific value should be improved by mixing the recyclable components of high calorific value.
- No separate treatment of Nirmalya was observed at solid waste management site. As considerable quantity of Nirmalya is generated in the city, the nirmalya collected from various places can be segregated and processed separately for its medicinal use (Hibiskas flowers for medicinal oil preparation) and vermicomposting instead of disposing it along with domestic solid waste.
- The leachate treated at Solid waste management site at Pathardi is applied on the land for gardening. The leachate mixed with the drains is used in agricultural field in smaller quantities. According to the general discharge standards prescribed by CPCB, the BOD limit for effluent discharge is 100mg/L for land application. The leachate generated at this site possesses very high level of BOD and COD values even after treatment. Hence application of such a quality of leachate may deteriorate soil as well as groundwater quality. Hence the leachate needs further treatment before applying on the land.

3.8.5 Issues of Concern

Adequacy of the Solid Waste Management Site : According to the census (2011) and ESR 2011, prepared by NMC, the population of Nashik is 14,87,000. The expected solid waste generation is 401 metric tons. The quantity considered by NMC for MSW generation is 392 and about 372 metric tons is collected. According to the CPCB norms for per capita solid waste generation, a city having

population more than 10 lakhs will generate 0.27 kg/capita/day domestic solid waste. The estimated quantity of MSW generation for 2026 is given in **Table 3.19**.

CPCB Norms for Generation of MSW in the Cities with Relation to Population

Population	Solid waste Generation	Units
10 -20 Lakhs	270	Grams/capita/day
>20Lakhs	300	Grams/capita/day
>30Lakhs	330	Grams/capita/day
>40 Lakhs	350	Grams/capita/day

Table 3.19 : Expected Quantity of MSW Generation in Nashik City for a Period of 2026

Particulars	Existing and Proposed Population			
	2011	2016	2021	2026
Population	14,87,000	18,11,197	25,96,278	31,70,851
Expected Waste Generation (M tons)	393/401	489	778*	1046*
Expected Waste collection (95% efficiency) (M tons)	372	464	739	994

* Considering 0.30 and 0.33kg/person/day production respectively

To evaluate the adequacy solid waste facility for future, the CPCB norms are considered. The existing plant has a design capacity off 300MT which is less than the waste generated. As solid waste generation will increase with population, compost plant at Pathardi will not be sufficient for solid waste treatment. Hence the capacity of the plant should be increased.

Additional Care is Essential on the Following Aspects :

- Provisions to avoid frequent incidences of Fire
- Attention to management of Electronic waste: It mainly includes the waste from electronic gadgets. As Nashik is well developed city, there must be significant generation of e-waste in city. Hence efforts should be made to quantify and planned proper management of e-waste.